

YY系列单相异步电动机 YY Series Single-Phase Induction Motors



机座号 50~90

功率 0.04~2.2kW

工作制 S1

绝缘等级 B

适用于: 适用于小型机床、医疗器械、家用电器、食品加工等机械的动力装置。

Applications: Widely used in medical apparatus, food pressing and small machine tools

特点: 性能优良, 节能省电, 结构可靠, 通用性强。

Features: Outstanding performance, reliable running

使用条件: 海拔不超过 1000m。环境温度随季节变化, 但最高不超过 +40°C, 最低不低于 -15°C。

Circumstance For Use: The altitude not exceeding 1000m above sea level. The ambient temperature subject to seasonal variations but not exceeding 40°C and not less than -15°C.

性能数据 Performance Data

220V 50Hz

型号 Type	功率 kW	转速 r/min	额定电流 Current A	效率 Eff. %	功率 因数 P.F	堵转转矩 额定转矩 $\frac{T_{st}}{T_N}$	堵转电流 额定电流 $\frac{I_{st}}{I_N}$	最大转矩 额定转矩 $\frac{T_{max}}{T_N}$	噪声 dB(A)
同步转速 3000r/min									
YY502-2	0.06	2800	1.5	53	0.90	0.50	2.0	1.7	65
YY561-2	0.09	2800	0.80	56	0.92	0.50	2.5	1.7	70
YY562-2	0.12	2800	0.99	60	0.92	0.50	3.5	1.7	70
YY631-2	0.18	2800	1.4	65	0.92	0.40	5.0	1.7	70
YY632-2	0.25	2800	1.9	66	0.92	0.40	7.0	1.7	70
YY711-2	0.37	2800	2.7	67	0.92	0.35	10.0	1.7	75
YY712-2	0.55	2800	3.9	70	0.92	0.35	15.0	1.7	75
YY801-2	0.75	2800	5.2	72	0.92	0.32	20	1.7	75
YY802-2	1.1	2800	7.1	75	0.95	0.32	30	1.7	78
YY90S-2	1.5	2800	9.5	76	0.95	0.30	45	1.7	83
YY90L-2	2.2	2800	13.7	77	0.95	0.30	65	1.7	83
同步转速 1500r/min									
YY502-4	0.04	1400	1.8	45	0.90	0.55	1.5	1.7	60
YY561-4	0.06	1400	0.61	50	0.90	0.45	2.0	1.7	65
YY562-4	0.09	1400	0.86	52	0.92	0.45	2.5	1.7	65
YY631-4	0.12	1400	1.1	57	0.90	0.40	3.5	1.7	65
YY632-4	0.18	1400	1.5	59	0.90	0.40	5.0	1.7	65
YY711-4	0.25	1400	2.0	61	0.92	0.35	7.0	1.7	65
YY712-4	0.37	1400	3.0	62	0.92	0.35	10.0	1.7	70
YY801-4	0.55	1400	4.3	64	0.92	0.35	15.0	1.7	70
YY802-4	0.75	1400	5.5	68	0.92	0.32	20.0	1.7	70
YY90S-4	1.1	1400	7.5	71	0.95	0.32	30.0	1.7	73
YY90L-4	1.5	1400	9.9	73	0.95	0.30	45.0	1.7	78

外形及安装尺寸 Dimensions

mm

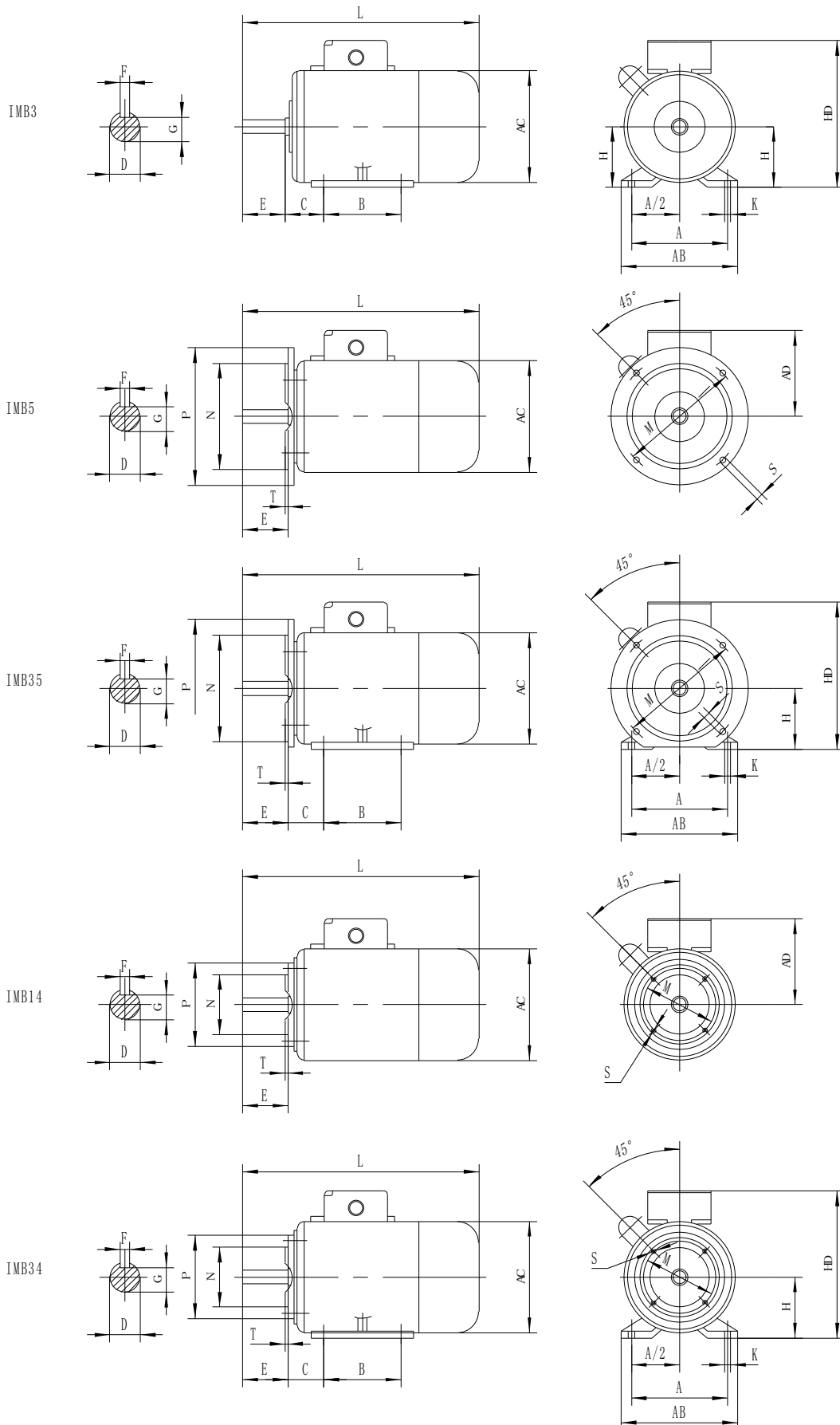

机座号 Frame	IMB3										IMB14 IMB34						IMB5 IMB35						IMB3				
	A	A/2	B	C	D	E	F	G	H	K	M	N	P	R	S	T	M	N	P	R	S	T	AB	AC	AD	HD	L
YY50	80	40	63	32	9	20	3	7.2	50	5.8	55	40	70	0	M5	2.5							10	110	10	12	15
YY56	90	45	71	36	9	20	3	7.2	56	5.8	65	50	80	0	M5	2.5							115	12	110	13	17
YY63	100	50	80	40	11	23	4	8.5	63	7	75	60	90	0	M5	2.5	115	95	140	0	10	3	13	13	12	16	25
YY71	112	56	90	45	14	30	5	11	71	7	85	70	105	0	M6	2.5	130	110	160	0	10	3.5	14	14	14	18	25
YY80	125	62.5	10	50	19	40	6	15.5	80	10	100	80	120	0	M8	3.0	165	130	200	0	12	3.5	16	16	15	20	29
YY90S	140	70	10	56	24	50	8	20	90	10	115	95	140	0	M8	3.0	165	130	200	0	12	3.5	18	18	16	24	37
YY90L	140	70	12	56	24	50	8	20	90	10	115	95	140	0	M8	3.0	165	130	200	0	12	3.5	18	18	16	24	40

注：IMB14、IMB34、IMB5 的其余尺寸见“IMB3”栏。The other dimensions of IMB14, IMB34 and IMB5 are the same as those of IMB3.