



YX3 系列

高效率三相异步电动机

YX3 SERIES HIGH-EFFICIENCY THREE PHASE INDUCTION MOTOR



安徽皖南电机股份有限公司
ANHUI WANNAN ELECTRIC MACHINE CO., LTD

概述 summary

机座号: 80~355 功率: 0.18~375kW
 工作制: S1 冷却方式: IC411
 能效等级: 中国GB18613-2012 3级 (IEC 2级)

适用于: 需要节能连续运行的一般使用场所。如风机、水泵等

Applications: Energy saving applications where continuous or frequent duty is required pumps, fans.

特点: 其外形美观、高效节能、F级绝缘, 防护等级为IP55, 电机噪声低、振动小, 运行可靠。

Features: These series motors have many virtues, including beautiful profile, high efficiency and energy saving, class F insulated, the protective class is IP55, low noise, little vibration, running smoothly,.

性能数据 Performance Data

380V 50Hz

型号 Type	功率 kW	额定 电流 A	转速 r/min	效率 Eff. %	功率 因数 P.F	额定 转矩 N.m	堵转转矩 额定转矩 $\frac{T_{st}}{T_N}$	堵转电流 额定电流 $\frac{I_{st}}{I_N}$	最大转矩 额定转矩 $\frac{T_{max}}{T_N}$	噪声 dB(A)
同步转速 3000 r/min										
YX3-80M1-2	0.75	1.8	2855	77.4	0.82	2.51	2.2	7.0	2.3	62
YX3-80M2-2	1.1	2.5	2870	79.6	0.83	3.66	2.2	7.3	2.3	62
YX3-90S-2	1.5	3.3	2865	81.3	0.84	5.0	2.2	7.6	2.3	67
YX3-90L-2	2.2	4.7	2870	83.2	0.85	7.32	2.2	7.6	2.3	67
YX3-100L-2	3	6.2	2875	84.6	0.87	10.0	2.2	7.8	2.3	74
YX3-112M-2	4	8.0	2910	85.8	0.88	13.1	2.2	8.3	2.3	77
YX3-132S1-2	5.5	10.9	2935	87.0	0.88	17.9	2.0	8.3	2.3	79
YX3-132S2-2	7.5	14.5	2930	88.1	0.89	24.4	2.0	7.9	2.3	79
YX3-160M1-2	11	21.0	2950	89.4	0.89	35.6	2.0	8.1	2.3	81
YX3-160M2-2	15	28.4	2945	90.3	0.89	48.6	2.0	8.1	2.3	81
YX3-160L-2	18.5	34.7	2945	90.9	0.89	60.0	2.0	8.2	2.3	81
YX3-180M-2	22	41.1	2950	91.3	0.89	71.2	2.0	8.2	2.3	83
YX3-200L1-2	30	55.7	2960	92.0	0.89	96.8	2.0	7.6	2.3	84
YX3-200L2-2	37	68.3	2960	92.5	0.89	119	2.0	7.6	2.3	84
YX3-225M-2	45	82.7	2965	92.9	0.89	145	2.0	7.7	2.3	86
YX3-250M-2	55	101	2970	93.2	0.89	177	2.0	7.1	2.3	89
YX3-280S-2	75	137	2975	93.8	0.89	241	1.8	7.1	2.3	91
YX3-280M-2	90	163	2970	94.1	0.89	289	1.8	7.1	2.3	91
YX3-315S-2	110	197	2975	94.3	0.90	353	1.8	7.1	2.3	92
YX3-315M-2	132	236	2975	94.6	0.90	424	1.8	7.1	2.3	92

性能数据 Performance Data

380V 50Hz

型号 Type	功率 kW	额定 电流 A	转速 r/min	效率 Eff.%	功率 因数 P.F	额定 转矩 N.m	堵转转矩 额定转矩 $\frac{T_{st}}{T_N}$	堵转电流 额定电流 $\frac{I_{st}}{I_N}$	最大转矩 额定转矩 $\frac{T_{max}}{T_N}$	噪声 dB(A)
同步转速 3000 r/min										
YX3-315L1-2	160	282	2975	94.8	0.91	514	1.8	7.2	2.3	92
YX3-315L-2	185	325	2975	94.9	0.91	594	1.8	7.2	2.3	92
YX3-315L2-2	200	352	2975	95.0	0.91	642	1.8	7.2	2.2	92
YX3-315L3-2	220	387	2975	95.0	0.91	706	1.8	7.2	2.2	92
YX3-355M1-2	220	387	2980	95.0	0.91	705	1.8	7.2	2.2	100
YX3-355M-2	250	439	2980	95.0	0.91	801	1.6	7.2	2.2	100
YX3-355L1-2	280	492	2980	95.0	0.91	897	1.6	7.2	2.2	100
YX3-355L-2	315	554	2980	95.0	0.91	1009	1.6	7.2	2.2	100
YX3-355L2-2	355	624	2980	95.0	0.91	1138	1.6	7.2	2.2	100
YX3-355L3-2	375	659	2980	95.0	0.91	1202	1.6	7.2	2.2	100
同步转速 1500 r/min										
YX3-80M1-4	0.55	1.4	1430	79.0	0.75	3.67	2.3	6.0	2.3	56
YX3-80M2-4	0.75	1.9	1425	79.6	0.76	5.03	2.3	6.6	2.3	56
YX3-90S-4	1.1	2.7	1420	81.4	0.77	7.40	2.3	6.8	2.3	59
YX3-90L-4	1.5	3.5	1420	82.8	0.78	10.1	2.3	7.0	2.3	59
YX3-100L1-4	2.2	5.0	1430	84.3	0.80	14.7	2.3	7.6	2.3	64
YX3-100L2-4	3	6.6	1430	85.5	0.81	20.0	2.3	7.6	2.3	64
YX3-112M-4	4	8.7	1450	86.6	0.81	26.3	2.2	7.8	2.3	65
YX3-132S-4	5.5	11.6	1465	87.7	0.82	35.9	2.0	7.9	2.3	71
YX3-132M-4	7.5	15.5	1465	88.7	0.83	48.9	2.0	7.5	2.3	71
YX3-160M-4	11	22.4	1470	89.8	0.83	71.5	2.0	7.7	2.3	73
YX3-160L-4	15	29.9	1470	90.6	0.84	97.4	2.0	7.8	2.3	73
YX3-180M-4	18.5	36.3	1470	91.2	0.85	120	2.0	7.8	2.3	76
YX3-180L-4	22	42.9	1465	91.6	0.85	143	2.0	7.8	2.3	76
YX3-200L-4	30	58.1	1475	92.3	0.85	194	2.0	7.3	2.3	76
YX3-225S-4	37	70.5	1480	92.7	0.86	239	2.0	7.4	2.3	78
YX3-225M-4	45	85.4	1480	93.1	0.86	290	2.0	7.4	2.3	78
YX3-250M-4	55	104	1485	93.5	0.86	354	2.0	7.4	2.3	79
YX3-280S-4	75	139	1490	94.0	0.87	481	2.0	6.9	2.3	80
YX3-280M-4	90	165	1485	94.2	0.88	579	2.0	6.9	2.3	80
YX3-315S-4	110	199	1485	94.5	0.89	707	2.0	7.0	2.2	88
YX3-315M-4	132	238	1485	94.7	0.89	849	2.0	7.0	2.2	88
YX3-315L1-4	160	285	1485	94.9	0.90	1029	2.0	7.1	2.2	88

性能数据 Performance Data

380V 50Hz

型号 Type	功率 kW	额定 电流 A	转速 r/min	效率 Eff.%	功率 因数 P.F	额定 转矩 N.m	堵转转矩 额定转矩 $\frac{T_{st}}{T_N}$	堵转电流 额定电流 $\frac{I_{st}}{I_N}$	最大转矩 额定转矩 $\frac{T_{max}}{T_N}$	噪声 dB(A)
同步转速 1500 r/min										
YX3-315L-4	185	329	1485	95.0	0.90	1190	2.0	7.1	2.2	88
YX3-315L2-4	200	355	1485	95.1	0.90	1286	2.0	7.1	2.2	88
YX3-315L3-4	220	391	1485	95.1	0.90	1415	2.0	7.1	2.2	88
YX3-355M1-4	220	391	1490	95.1	0.90	1410	2.0	7.1	2.2	95
YX3-355M-4	250	444	1490	95.1	0.90	1602	2.0	7.1	2.2	95
YX3-355L1-4	280	497	1490	95.1	0.90	1795	2.0	7.1	2.2	95
YX3-355L-4	315	559	1490	95.1	0.90	2019	2.0	7.1	2.2	95
YX3-355L2-4	355	645	1490	95.1	0.88	2275	1.7	7.0	2.2	95
YX3-355L3-4	375	681	1490	95.1	0.88	2404	1.7	7.0	2.2	95
同步转速 1000 r/min										
YX3-80M1-6	0.37	1.2	910	67.0	0.70	3.88	1.9	5.5	2.1	54
YX3-80M2-6	0.55	1.7	910	70.0	0.71	5.77	1.9	5.5	2.1	54
YX3-90S-6	0.75	2.1	935	75.9	0.71	7.66	2.0	6.0	2.1	57
YX3-90L-6	1.1	3.0	935	78.1	0.72	11.2	2.0	6.0	2.1	57
YX3-100L-6	1.5	4.0	945	79.8	0.72	15.2	2.0	6.5	2.1	61
YX3-112M-6	2.2	5.7	965	81.8	0.72	21.8	2.0	6.6	2.1	65
YX3-132S-6	3	7.6	975	83.3	0.72	29.4	1.9	6.8	2.1	69
YX3-132M1-6	4	9.7	975	84.6	0.74	39.2	1.9	6.8	2.1	69
YX3-132M2-6	5.5	13.0	975	86.0	0.75	53.9	1.9	7.0	2.1	69
YX3-160M-6	7.5	16.8	975	87.2	0.78	73.5	2.0	7.0	2.1	70
YX3-160L-6	11	23.9	975	88.7	0.79	108	2.0	7.2	2.1	70
YX3-180L-6	15	31.8	980	89.7	0.80	146	1.9	7.3	2.1	73
YX3-200L1-6	18.5	38.9	980	90.4	0.80	180	1.9	7.3	2.1	73
YX3-200L2-6	22	45.4	980	90.9	0.81	214	1.9	7.4	2.1	73
YX3-225M-6	30	60.6	985	91.7	0.82	291	1.9	6.9	2.1	74
YX3-250M-6	37	73.5	985	92.2	0.83	359	1.9	7.1	2.1	76
YX3-280S-6	45	86.8	990	92.7	0.85	434	1.9	7.3	2.0	78
YX3-280M-6	55	104	990	93.1	0.86	531	1.9	7.3	2.0	78
YX3-315S-6	75	145	990	93.7	0.84	723	1.9	6.6	2.0	83
YX3-315M-6	90	171	990	94.0	0.85	868	1.9	6.7	2.0	83
YX3-315L1-6	110	209	990	94.3	0.85	1061	1.9	6.7	2.0	83
YX3-315L2-6	132	247	990	94.6	0.86	1273	1.9	6.8	2.0	83
YX3-315L3-6	160	298	990	94.8	0.86	1543	1.9	6.8	2.0	83

性能数据 Performance Data

380V 50Hz

型号 Type	功率 kW	额定 电流 A	转速 r/min	效率 Eff.%	功率 因数 P.F	额定 转矩 N.m	堵转转矩 额定转矩 $\frac{T_{st}}{T_N}$	堵转电流 额定电流 $\frac{I_{st}}{I_N}$	最大转矩 额定转矩 $\frac{T_{max}}{T_N}$	噪声 dB(A)
同步转速 1000 r/min										
YX3-355M1-6	160	298	990	94.8	0.86	1543	1.9	6.8	2.0	85
YX3-355M-6	185	344	990	94.9	0.86	1785	1.9	6.8	2.0	85
YX3-355M2-6	200	372	990	95.0	0.86	1929	1.9	6.8	2.0	85
YX3-355L1-6	220	409	990	95.0	0.86	2122	1.9	6.8	2.0	85
YX3-355L-6	250	465	990	95.0	0.86	2412	1.9	6.8	2.0	85
YX3-355L2-6	280	521	990	95.0	0.86	2701	1.9	6.8	2.0	85
YX3-355L3-6	315	586	995	95.0	0.86	3023	1.9	6.8	2.0	85
同步转速 750 r/min										
YX3-80M1-8	0.18	0.8	700	52.8	0.61	2.46	1.8	3.3	1.9	52
YX3-80M2-8	0.25	1.1	700	57	0.61	3.41	1.8	3.3	1.9	52
YX3-90S-8	0.37	1.4	695	64	0.62	5.08	1.8	4.0	2.0	56
YX3-90L-8	0.55	2.0	695	67.5	0.63	7.56	1.8	4.0	2.0	56
YX3-100L1-8	0.75	2.3	705	71.5	0.68	10.2	1.8	4.0	2.0	59
YX3-100L2-8	1.1	3.3	705	74.5	0.69	14.9	1.8	4.0	2.0	59
YX3-112M-8	1.5	4.4	715	75.4	0.69	20.0	1.8	4.0	2.0	61
YX3-132S-8	2.2	6.0	730	78.2	0.71	28.8	1.8	5.5	2.2	64
YX3-132M-8	3	7.7	730	80.6	0.73	39.2	1.8	5.5	2.2	64
YX3-160M1-8	4	10.1	725	82.7	0.73	52.7	1.9	6.0	2.2	68
YX3-160M2-8	5.5	13.4	725	84.3	0.74	72.4	1.9	6.0	2.2	68
YX3-160L-8	7.5	17.7	730	85.8	0.75	98.1	1.9	6.0	2.2	68
YX3-180L-8	11	25.0	725	87.8	0.76	145	1.9	6.0	2.2	70
YX3-200L-8	15	33.7	730	89.0	0.76	196	2.0	6.5	2.2	73
YX3-225S-8	18.5	40.0	735	90.2	0.78	240	2.0	6.5	2.2	73
YX3-225M-8	22	47.4	735	90.5	0.78	286	2.0	6.5	2.2	73
YX3-250M-8	30	63.4	735	91	0.79	390	1.9	6.5	2.0	75
YX3-280S-8	37	77.8	740	91.5	0.79	478	1.8	6.0	2.0	76
YX3-280M-8	45	93.9	740	92.2	0.79	581	1.8	6.0	2.0	76
YX3-315S-8	55	111	740	93.1	0.81	710	1.8	6.5	2.0	82
YX3-315M-8	75	151	740	93.2	0.81	968	1.8	6.5	2.0	82
YX3-315L1-8	90	181	740	93.2	0.81	1161	1.8	6.5	2.0	82
YX3-315L2-8	110	218	740	93.5	0.82	1420	1.8	6.5	2.0	82
YX3-355M1-8	132	261	745	93.7	0.82	1692	1.8	6.5	2.0	90
YX3-355M2-8	160	314	745	94.3	0.82	2051	1.8	6.5	2.0	90

性能数据 Performance Data

380V 50Hz

型号 Type	功率 kW	额定 电流 A	转速 r/min	效率 Eff.%	功率 因数 P.F	额定 转矩 N.m	堵转转矩 额定转矩 $\frac{T_{st}}{T_N}$	堵转电流 额定电流 $\frac{I_{st}}{I_N}$	最大转矩 额定转矩 $\frac{T_{max}}{T_N}$	噪声 dB(A)
同步转速 750 r/min										
YX3-355L1-8	185	364	745	94.3	0.82	2371	1.8	6.5	2.0	90
YX3-355L-8	200	392	745	94.5	0.82	2564	1.8	6.5	2.0	90
YX3-355L2-8	220	431	745	94.5	0.82	2820	1.8	6.5	2.0	90
YX3-355L3-8	250	484	745	94.5	0.83	3205	1.8	6.5	2.0	90
同步转速 600 r/min										
YX3-315S-10	45	100	590	91.5	0.75	728	1.5	6.0	2.0	90
YX3-315M-10	55	121	590	92.0	0.75	890	1.5	6.0	2.0	90
YX3-315L1-10	75	162	590	92.5	0.76	1214	1.5	6.0	2.0	90
YX3-315L2-10	90	191	590	93.0	0.77	1457	1.5	6.0	2.0	90
YX3-355M1-10	110	230	595	93.2	0.78	1766	1.3	5.5	2.0	90
YX3-355M2-10	132	275	595	93.6	0.78	2119	1.3	5.5	2.0	90
YX3-355L1-10	160	333	595	93.6	0.78	2568	1.3	5.5	2.0	90
YX3-355L-10	185	385	595	93.6	0.78	2969	1.3	5.5	2.0	90
YX3-355L2-10	200	416	595	93.6	0.78	3210	1.3	5.5	2.0	90
YX3-355L3-10	220	458	595	93.6	0.78	3531	1.3	5.5	2.0	90
同步转速 500 r/min										
YX3-355M1-12	55	126	495	92.0	0.72	1061	1.4	6.0	2.0	90
YX3-355M2-12	75	169	495	92.5	0.73	1447	1.4	6.0	2.0	90
YX3-355L1-12	90	199	495	92.8	0.74	1736	1.3	6.0	2.0	90
YX3-355L-12	110	240	495	93.0	0.75	2122	1.3	6.0	2.0	90
YX3-355L2-12	132	287	495	93.2	0.75	2547	1.3	6.0	2.0	90

常用的安装结构型式，以及适用的机座号见下表

Conventional mounting type and suitable frame size are given in following table (with “√”)

机座号 Frame	基本安装结构 basic type			派生的安装形式 derived type											
	B3	B5	B35	V1	V3	V5	V6	B6	B7	B8	V15	V36	B14	B34	V18
80~112	√	√	√	√	√	√	√	√	√	√	√	√	√	√	√
132~160	√	√	√	√	√	√	√	√	√	√	√	√	-	-	-
180~280	√	√	√	√	-	-	-	-	-	-	-	-	-	-	-
315~355	√	-	√	√	-	-	-	-	-	-	-	-	-	-	-

注：“√”表示可以制造生产的结构型式，电机订购时，若不作说明的接线盒为侧式右出线。

外形及安装尺寸 Dimensions

mm

B14 (机座无底脚、端盖上有小凸缘)

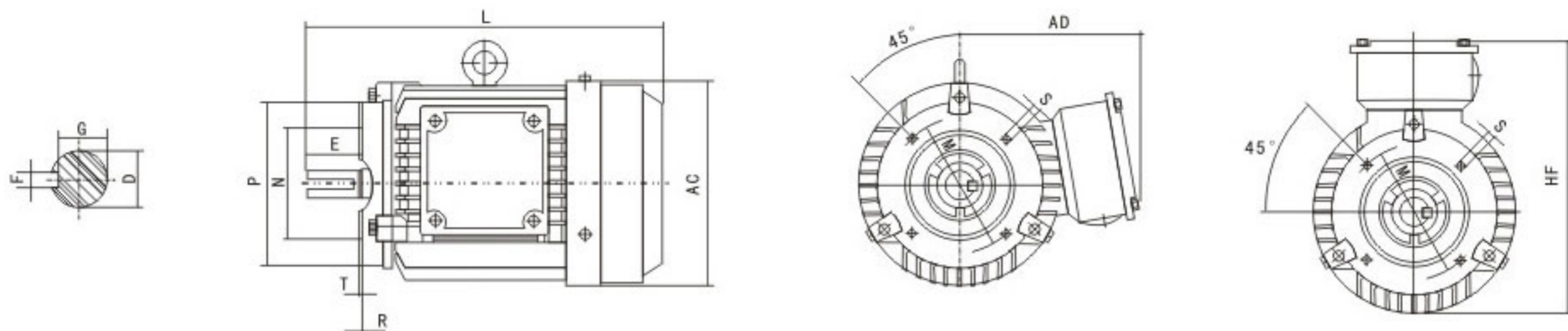

机座号 Frame	极数 Poles	安装尺寸及公差 Mounting Dimension											外形尺寸 Overall Dimension			
		D	E	F	G	M	N	P	R	S	T	AC	AD	HF	L	
80M	2,4,6,8	19	40	6	15.5	100	80	120	0	4-M6	3	165	145	245	295	
90S	2,4,6,8	24	50	8	20	115	95	140	0	4-M8	3	180	165	265	320	
90L	2,4,6,8														345	
100L	2,4,6,8	28	60	8	24	130	110	160	0	4-M8	3.5	205	175	300	390	
112M	2,4,6,8	28	60	8	24	130	110	160	0	4-M8	3.5	225	190	315	420	

B34 (机座带底脚、端盖上有小凸缘)

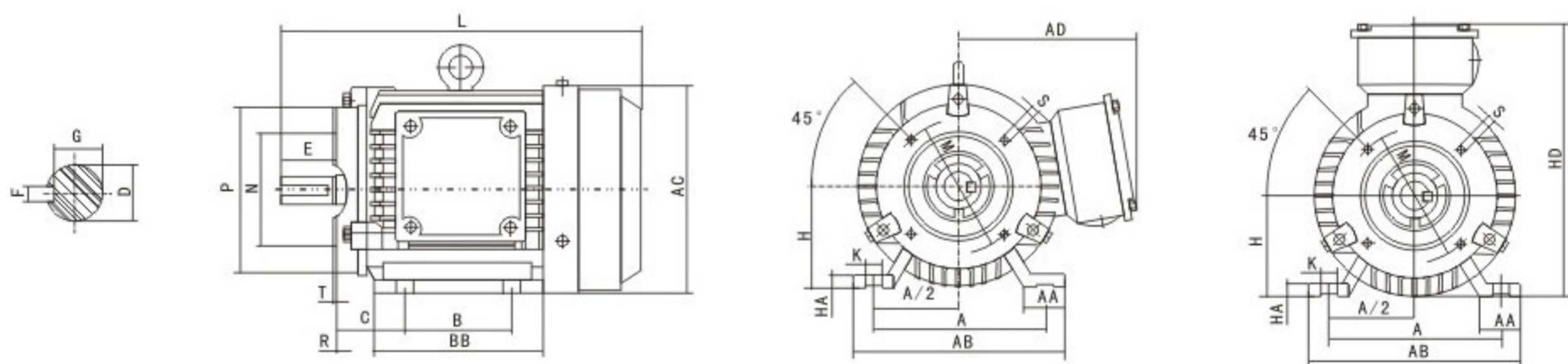

机座号 Frame	极数 Poles	安装尺寸及公差 Mounting Dimension															外形尺寸 Overall Dimension							
		A	B	C	D	E	F	G	H	K	M	N	P	R	S	T	AA	BB	HA	AB	AC	AD	HD	L
80M	2,4,6,8	125	100	50	19	40	6	15.5	80	10	100	80	120	0	4-M6	3	32	135	10	160	165	145	225	295
90S	2,4,6,8	140	100	56	24	50	8	20	90	10	115	95	140	0	4-M8	3	34	145	12	180	180	165	255	320
90L	2,4,6,8		125															170						345
100L	2,4,6,8	160	140	63	28	60	8	24	100	12	130	110	160	0	4-M8	3.5	39	186	14	200	205	175	275	390
112M	2,4,6,8	190	140	70	28	60	8	24	112	12	130	110	160	0	4-M8	3.5	45	200	14	230	225	190	300	420

外形及安装尺寸 Dimensions

mm

B3 (机座带底脚、端盖无凸缘)

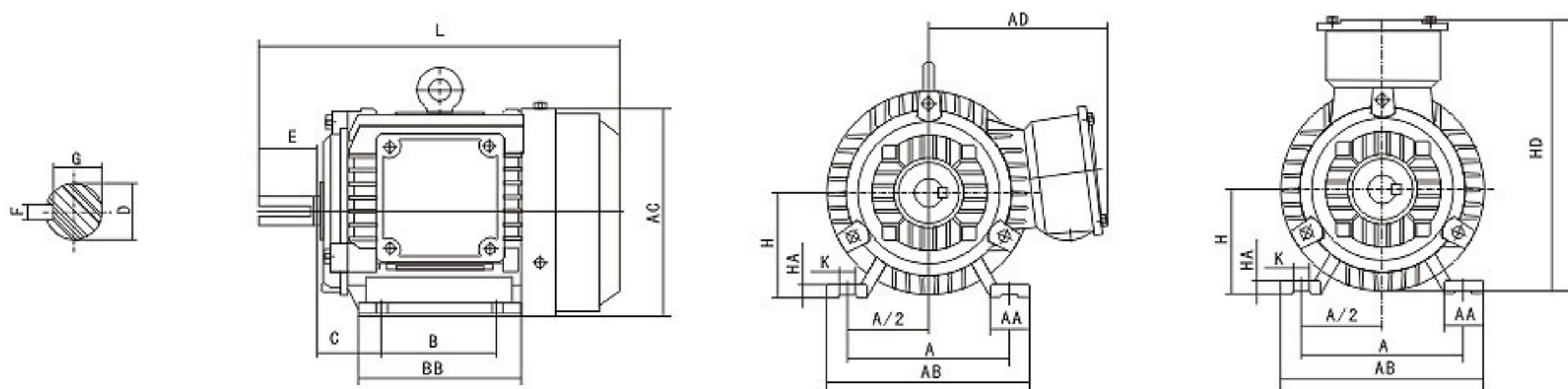

机座号 Frame	极数 Poles	安装尺寸及公差 Mounting Dimension									外形尺寸 Overall Dimension							
		A	B	C	D	E	F	G	H	K	AA	BB	HA	AB	AC	AD	HD	L
80M	2,4,6,8	125	100	50	19	40	6	15.5	80	10	32	135	10	160	165	145	225	295
90S	2,4,6,8	140	100	56	24	50	8	20	90	10	34	145	12	180	180	165	255	320
90L			125									170						345
100L	2,4,6,8	160	140	63	28	60	8	24	100	12	39	186	14	200	205	175	275	390
112M	2,4,6,8	190	140	70	28	60	8	24	112	12	45	200	14	230	225	190	300	420
132S	2,4,6,8	216	140	89	38	80	10	33	132	12	55	190	18	265	270	220	350	470
132M			178									230						510
160M	2,4,6,8	254	210	108	42	110	12	37	160	15	65	260	20	315	320	260	420	610
160L			254									304						650
180M	2,4,6,8	279	241	121	48	110	14	42.5	180	15	70	311	22	355	360	265	445	685
180L			279									349						725
200L	2,4,6,8	318	305	133	55	110	16	49	200	19	74	379	26	395	400	305	505	775
225S	4,8	356	286	149	60	140	18	53	225	19	78	375	28	435	450	325	550	815
225M	2		311		55	110	16	49				400						810
	4,6,8				60	140	18	53										840
250M	2	406	349	168	60	140	18	53	250	24	80	445	30	490	510	380	630	920
	4,6,8				65			58										
280S	2	457	368	190	65	140	18	58	280	24	90	485	35	545	550	395	675	965
	4,6,8				75			67.5										
280M	2	457	419	190	65	140	18	58	280	24	90	536	35	545	550	395	675	1015
	4,6,8				75			67.5										
315S	2	508	406	216	65	140	18	58	315	28	120	570	45	635	630	540	855	1180
	4,6,8,10				80			71										1210
315M	2	508	457	216	65	140	18	58	315	28	120	610	45	635	630	540	855	1215
	4,6,8,10				80			71										1245
315L	2	508	406	216	65	140	18	58	315	28	120	680	45	635	630	540	855	1290
	4,6,8,10				80			71										1320
355M	2	610	560	254	75	140	20	67.5	355	28	130	690	52	735	715	645	1000	1390
	4,6,8,10,12				95			86										1420
355L/L1	2	610	630	254	75	140	20	67.5	355	28	130	750	52	735	715	645	1000	1500
	4,6,8,10,12				95			86										1530
355L2/L3	2	610	630	254	80	170	22	71	355	28	130	750	52	735	715	645	1000	1530
	4,6,8,10,12				110			100										1570

外形及安装尺寸 Dimensions

mm

B5 (机座不带底脚、端盖有凸缘)

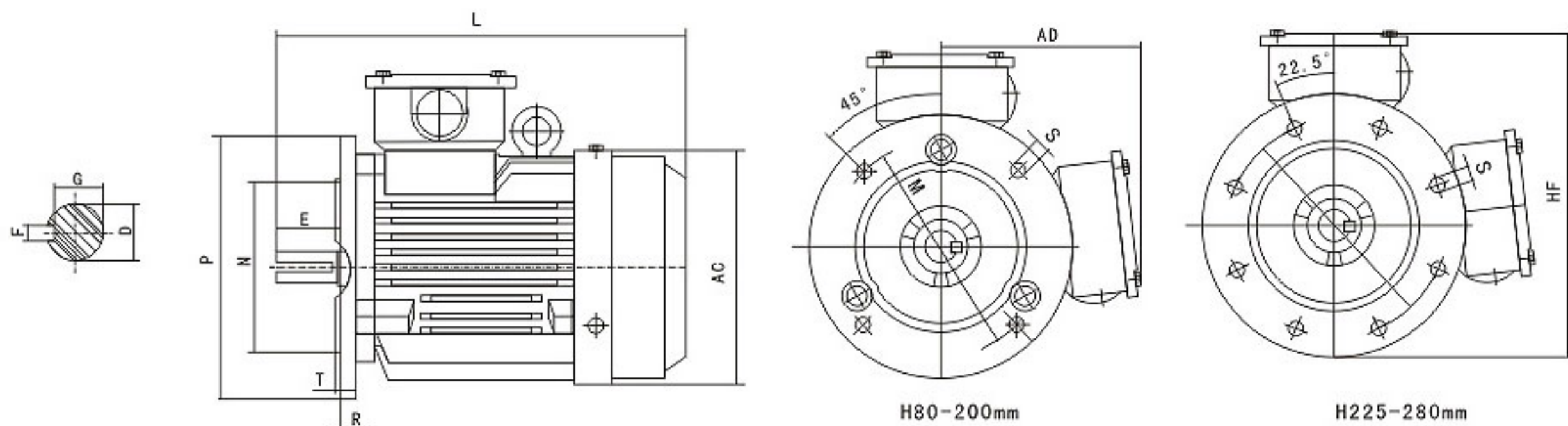

机座号 Frame	极数 Poles	安装尺寸及公差 Mounting Dimension										外形尺寸 Overall Dimension			
		D	E	F	G	M	N	P	R	S	T	AC	AD	HF	L
80M	2,4,6,8	19	40	6	15.5	165	130	200	0	4-Φ12	3.5	165	145	245	295
90S	2,4,6,8	24	50	8	20	165	130	200	0	4-Φ12	3.5	180	165	265	320
90L															345
100L	2,4,6,8	28	60	8	24	215	180	250	0	4-Φ15	4	205	175	300	390
112M	2,4,6,8														225
132S	2,4,6,8	38	80	10	33	265	230	300	0	4-Φ15	4	270	220	370	470
132M															510
160M	2,4,6,8	42	110	12	37	300	250	350	0	4-Φ19	5	320	260	435	610
160L															650
180M	2,4,6,8	48	110	14	42.5	300	250	350	0	4-Φ19	5	360	265	440	685
180L															725
200L	2,4,6,8	55	110	16	49	350	300	400	0	4-Φ19	5	400	305	505	775
225S	4,8	60	140	18	53	400	350	450	0	8-Φ19	5	450	325	550	815
225M	2	55	110	16	49										810
	4,6,8	60	140	18	53										840
250M	2	60	140	18	53	500	450	550	0	8-Φ19	5	510	380	655	920
	4,6,8	65	58												
280S	2	65	140	18	58	500	450	550	0	8-Φ19	5	550	395	670	965
	4,6,8	75		20	67.5										
280M	2	65		18	58										1015
	4,6,8	75		20	67.5										

外形及安装尺寸 Dimensions

mm

B35 (机座带底脚、端盖有凸缘)

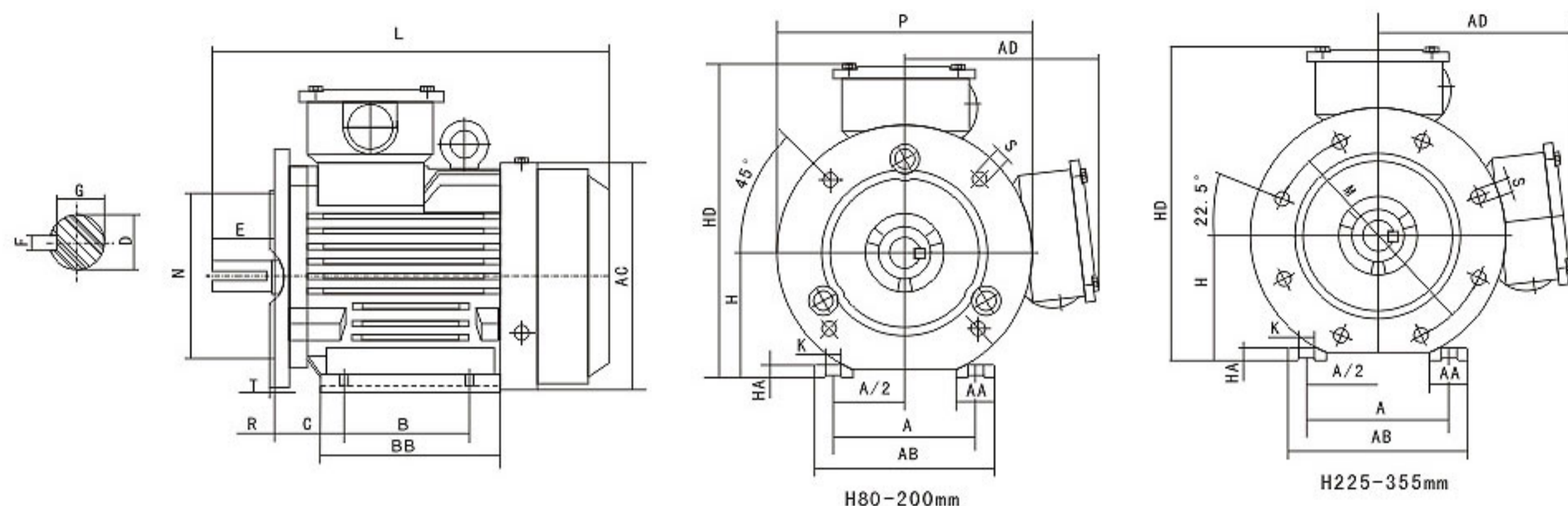

机座号 Frame	极数 Poles	安装尺寸及公差 Mounting Dimension															外形尺寸 Overall Dimension							
		A	B	C	D	E	F	G	H	K	M	N	P	R	S	T	AA	BB	HA	AB	AC	AD	HD	L
80M	2,4,6,8	125	100	50	19	40	6	15.5	80	10	165	130	200	0	4-Φ12	3.5	32	135	10	160	165	145	225	295
90S	2,4,6,8	140	100	56	24	50	8	20	90	10	165	130	200	0	4-Φ12	3.5	34	145	12	180	180	165	255	320
90L			170															345						
100L	2,4,6,8	160	140	63	28	60	8	24	100	12	215	180	250	0	4-Φ15	4	39	186	14	200	205	175	275	390
112M	2,4,6,8	190	140	70					112								45	200						
132S	2,4,6,8	216	140	89	38	80	10	33	132	15	265	230	300	0	4-Φ19	5	55	190	18	265	270	220	350	470
132M			230														510							
160M	2,4,6,8	254	210	108	42	110	12	37	160	15	300	250	350	0	4-Φ19	5	65	260	20	315	320	260	420	610
160L			304														650							
180M	2,4,6,8	279	241	121	48	110	14	42.5	180	15	300	250	350	0	4-Φ19	5	70	311	22	355	360	265	445	685
180L			349														725							
200L	2,4,6,8	318	305	133	55	110	16	49	200	19	350	300	400	0	4-Φ19	5	74	379	26	395	400	305	505	775
225S	4,8	356	286	149	60	140	18	53	225	19	400	350	450	0	8-Φ19	5	78	375	28	435	450	325	550	815
225M	2		311		55	110	16	49										53						80
250M	2	406	349	168	60	140	18	53	250	24	500	450	550	0	8-Φ19	5	80	445	35	545	550	395	675	1015
280S	4,6,8				368													75						
280M	2	457	419	190	65	140	18	58	280	24	500	450	550	0	8-Φ24	6	120	536	45	635	630	540	855	1245
315S	4,6,8,10				406													80						
315M	2	508	457	216	65	140	18	58	315	28	600	550	660	0	8-Φ24	6	120	610	45	635	630	540	855	1290
315L	4,6,8,10				508																			80
355M	2	610	560	254	75	140	20	67.5	355	28	740	680	800	0	8-Φ24	6	130	690	52	735	715	645	1000	1390
355L/L1	4,6,8,10,12				630																			95
355L2/L3	2	610	560	254	75	140	20	67.5	355	28	740	680	800	0	8-Φ24	6	130	690	52	735	715	645	1000	1530
355L2/L3	4,6,8,10,12				630																			80
355L2/L3	2	610	560	254	110	210	28	100	355	28	740	680	800	0	8-Φ24	6	130	690	52	735	715	645	1000	1570
355L2/L3	4,6,8,10,12				630																			110

外形及安装尺寸 Dimensions

mm

V1 (立式安装、机座不带底脚、端盖有凸缘、轴伸向下的电动机)

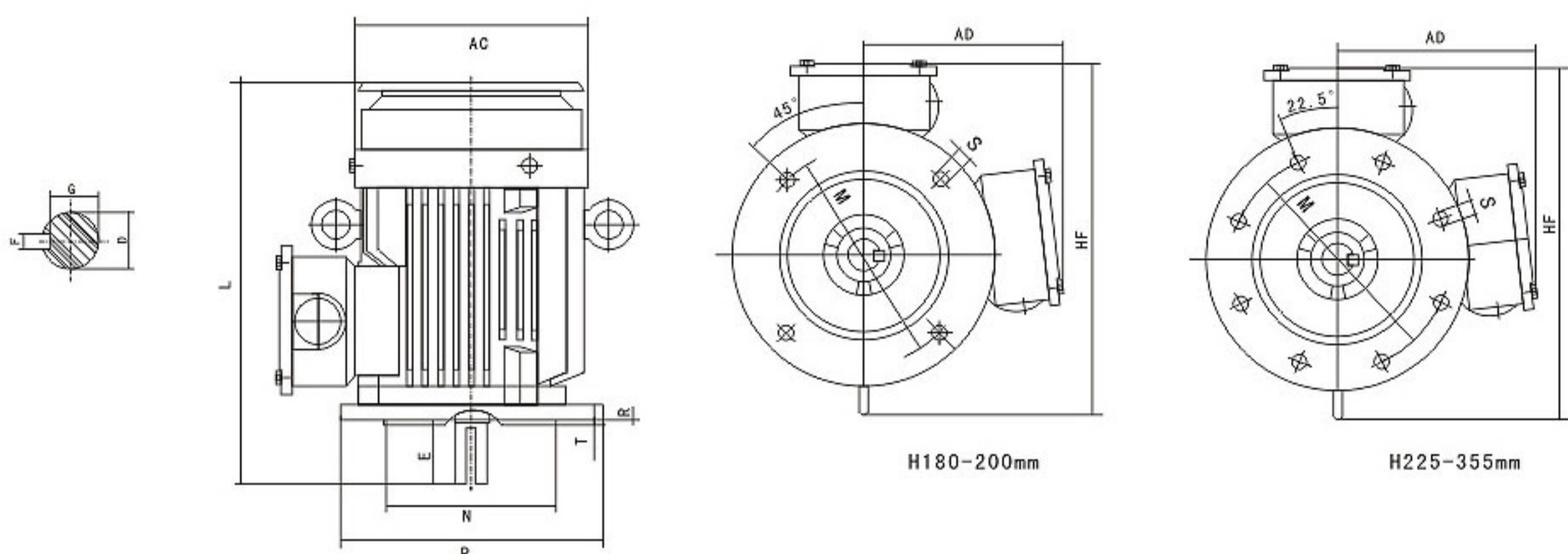

机座号 Frame	极数 Poles	安 装 尺 寸 Mouting Dimension										外形尺寸 Overall Dimension			
		D	E	F	G	M	N	P	R	S	T	AC	AD	HF	L
180M	2,4,6,8	48	110	14	42.5	300	250	350	0	4-Φ19	5	360	265	500	745
180L															785
200L	2,4,6,8	55	110	16	49	350	300	400	0	4-Φ19	5	400	305	570	845
225S	4,8	60	140	18	53	400	350	450	0	8-Φ19	5	450	325	615	905
225M	2	55	110	16	49										900
		4,6,8	60	140	18	53	930								
250M	2	60	140	18	53	500	450	550	0	8-Φ19	5	510	380	715	1025
	4,6,8	65													58
280S	2	65	140	18	58	500	450	550	0	8-Φ19	5	550	395	760	1080
	4,6,8	75		20	67.5										
280M	2	65		18	58										1130
	4,6,8	75		20	67.5										
315S	2	65	140	18	58	600	550	660	0	8-Φ24	6	630	540	970	1310
	4,6,8,10	80	170	22	71										1340
315M	2	65	140	18	58	740	680	800	0	8-Φ24	6	715	645	1135	1345
	4,6,8,10	80	170	22	71										1375
315L	2	65	140	18	58	740	680	800	0	8-Φ24	6	715	645	1135	1420
	4,6,8,10	80	170	22	71										1450
355M	2	75	140	20	67.5	740	680	800	0	8-Φ24	6	715	645	1135	1530
	4,6,8,10,12	95	170	25	86										1560
355L/L1	2	75	140	20	67.5	740	680	800	0	8-Φ24	6	715	645	1135	1640
	4,6,8,10,12	95	170	25	86										1670
355L2/L3	2	80	170	22	71	740	680	800	0	8-Φ24	6	715	645	1135	1670
	4,6,8,10,12	110	210	28	100										1710



YX3 系列

高效率三相异步电动机

YX3 SERIES HIGH - EFFICIENCY THREE PHASE INDUCTION MOTOR

公司地址：安徽省泾县南华路86号

邮政编码：242500

电话：0563-5031988 5023698

传真：0563-5029999（销售处）5023608

网址：<http://www.wnmotor.com>

电子信箱：Sales@wnmotor.com（销售处）

Wndjc@wnmotor.com（公司）

Address:86.nanhua road Jingxian County,Anhui Province

Zip code:242500

Tel:0563-5031988 5023698

Fax:0563-5029999（销售处）5023608

<http://www.wnmotor.com>

E-mail:Sales@wnmotor.com(sales department)

Wndjc@wnmotor.com(headquatter)