

YE4 系列三相异步电动机

YE4 Series Three Phase Induction Motors

一、概述



机座号 80~355

功率 0.75~375kW

工作制 S1

冷却方式: IC411

能效等级: GB18613-2020 2级 (IE 4)

适用于: 需要节能连续运行的一般使用场所, 如风机、水泵、机床等。

Applications: Can be applied in the machines where continuous duty is required, like pumps, fans, machine etc.

特点: 外形美观、高效节能(效率符合 GB18613-2020 或 IEC 60034-30-1:2014 中 IE4 的效率等级), F 级绝缘, 防护等级为 IP55, 电机噪声低、振动小, 运行可靠。

Features: Beautiful profile, high efficiency and energy saving (level 2 of GB18613-2020 or IEC 60034-30-1:2014 IE4), class F insulation, IP55 protection grade, low noise, little vibration, reliable running.

性能数据 Performance Data

380V 50Hz

型号 Type	功率 kW	额定 电流 A	转速 r/min	效率 Eff.%	功率 因数 P.F	额定 转矩 N.m	堵转转矩 额定转矩 $\frac{T_{st}}{T_N}$	堵转电流 额定电流 $\frac{I_{st}}{I_N}$	最大转矩 额定转矩 $\frac{T_{max}}{T_N}$	噪声 dB(A)
同步转速 3000 r/min										
YE4-80M1-2	0.75	1.6	2895	83.5	0.83	2.47	2.2	8.5	2.3	62
YE4-80M2-2	1.1	2.4	2890	85.2	0.83	3.63	2.2	8.5	2.3	62
YE4-90S-2	1.5	3.1	2880	86.5	0.85	4.97	2.2	9.0	2.3	67
YE4-90L-2	2.2	4.4	2880	88.0	0.86	7.30	2.2	9.0	2.3	67
YE4-100L-2	3	5.9	2905	89.1	0.87	9.86	2.2	9.5	2.3	74
YE4-112M-2	4	7.7	2920	90.0	0.88	13.1	2.2	9.5	2.3	77
YE4-132S1-2	5.5	10.4	2945	90.9	0.88	17.8	2.0	9.5	2.3	79
YE4-132S2-2	7.5	14.1	2940	91.7	0.89	24.4	2.0	9.5	2.3	79
YE4-160M1-2	11	20.3	2965	92.6	0.89	35.4	2.0	9.5	2.3	81
YE4-160M2-2	15	27.4	2965	93.3	0.89	48.3	2.0	9.5	2.3	81
YE4-160L-2	18.5	33.7	2965	93.7	0.89	59.6	2.0	9.5	2.3	81
YE4-180M-2	22	40.0	2970	94.0	0.89	70.7	2.0	9.5	2.3	83
YE4-200L1-2	30	54.2	2965	94.5	0.89	96.6	2.0	9.0	2.3	84
YE4-200L2-2	37	66.6	2965	94.8	0.89	119	2.0	9.0	2.3	84
YE4-225M-2	45	80.9	2970	95.0	0.89	145	2.0	9.0	2.3	86
YE4-250M-2	55	98.5	2980	95.3	0.89	176	2.0	9.0	2.3	89
YE4-280S-2	75	134	2975	95.6	0.89	241	1.8	8.5	2.3	91
YE4-280M-2	90	160	2975	95.8	0.89	289	1.8	8.5	2.3	91
YE4-315S-2	110	196	2985	96.0	0.89	352	1.8	8.5	2.3	92
YE4-315M-2	132	234	2985	96.2	0.89	422	1.8	8.5	2.3	92
YE4-315L1-2	160	284	2985	96.3	0.89	512	1.8	8.5	2.2	92
YE4-315L-2	185	328	2985	96.4	0.89	592	1.8	8.5	2.2	92

性能数据 Performance Data

380V 50Hz

型号 Type	功率 kW	额定 电流 A	转速 r/min	效率 Eff. %	功率 因数 P.F	额定 转矩 N.m	堵转转矩 额定转矩 $\frac{T_{st}}{T_N}$	堵转电流 额定电流 $\frac{I_{st}}{I_N}$	最大转矩 额定转矩 $\frac{T_{max}}{T_N}$	噪声 dB(A)
同步转速 3000 r/min										
YE4-315L2-2	200	354	2985	96.5	0.89	640	1.8	8.5	2.2	92
YE4-315L3-2	220	389	2985	96.5	0.89	704	1.8	8.5	2.2	92
YE4-315L4-2	250	433	2985	96.5	0.91	800	1.8	8.5	2.2	92
YE4-355M1-2	220	389	2985	96.5	0.89	704	1.8	8.5	2.2	97
YE4-355M-2	250	433	2985	96.5	0.91	800	1.6	8.5	2.2	97
YE4-355L1-2	280	484	2985	96.5	0.91	896	1.6	8.5	2.2	97
YE4-355L-2	315	545	2985	96.5	0.91	1008	1.6	8.5	2.2	97
YE4-355 1-2	355	621	2985	96.5	0.90	1136	0.9	8.6	1.8	97
YE4-355 2-2	375	656	2985	96.5	0.90	1200	0.9	8.6	1.8	97
同步转速 1500 r/min										
YE4-80M1-4	0.55	1.4	1440	83.9	0.73	3.65	2.4	6.6	2.3	56
YE4-80M2-4	0.75	1.8	1440	85.7	0.74	4.97	2.3	8.5	2.3	56
YE4-90S-4	1.1	2.6	1445	87.2	0.75	7.27	2.3	8.5	2.3	59
YE4-90L-4	1.5	3.4	1445	88.2	0.76	9.91	2.3	9.0	2.3	59
YE4-100L1-4	2.2	4.7	1450	89.5	0.79	14.5	2.3	9.0	2.3	64
YE4-100L2-4	3	6.3	1450	90.4	0.80	19.8	2.3	9.5	2.3	64
YE4-112M-4	4	8.3	1460	91.1	0.80	26.2	2.3	9.5	2.3	65
YE4-132S-4	5.5	11.4	1475	91.9	0.80	35.6	2.0	9.5	2.3	71
YE4-132M-4	7.5	15.2	1470	92.6	0.81	48.7	2.0	9.5	2.3	71
YE4-160M-4	11	21.6	1470	93.3	0.83	71.5	2.0	9.5	2.3	73
YE4-160L-4	15	28.9	1470	93.9	0.84	97.4	2.0	9.5	2.3	73
YE4-180M-4	18.5	35.1	1475	94.2	0.85	120	2.0	9.5	2.3	76
YE4-180L-4	22	41.6	1475	94.5	0.85	142	2.0	9.5	2.3	76
YE4-200L-4	30	56.5	1485	94.9	0.85	193	2.0	9.0	2.3	76
YE4-225S-4	37	69.5	1490	95.2	0.85	237	2.0	9.0	2.3	78
YE4-225M-4	45	84.3	1485	95.4	0.85	289	2.0	9.0	2.3	78
YE4-250M-4	55	102	1485	95.7	0.86	354	2.0	9.0	2.3	79
YE4-280S-4	75	136	1490	96.0	0.87	481	2.0	8.5	2.3	80
YE4-280M-4	90	162	1490	96.1	0.88	577	2.0	8.5	2.3	80
YE4-315S-4	110	195	1490	96.3	0.89	705	1.8	8.5	2.2	88
YE4-315M-4	132	234	1490	96.4	0.89	846	1.8	8.5	2.2	88
YE4-315L1-4	160	280	1490	96.6	0.90	1026	1.8	8.5	2.2	88
YE4-315L-4	185	323	1490	96.7	0.90	1186	1.8	8.5	2.2	88
YE4-315L2-4	200	349	1490	96.7	0.90	1282	1.8	8.5	2.2	88
YE4-315L3-4	220	384	1490	96.7	0.90	1410	1.8	8.5	2.2	88
YE4-315L4-4	250	436	1490	96.7	0.90	1602	1.8	8.5	2.2	88
YE4-355M1-4	220	384	1490	96.7	0.90	1410	1.8	8.5	2.2	92
YE4-355M-4	250	436	1495	96.7	0.90	1597	1.8	8.5	2.2	92
YE4-355L1-4	280	489	1495	96.7	0.90	1789	1.8	8.5	2.2	92
YE4-355L-4	315	550	1490	96.7	0.90	2019	1.8	8.5	2.2	92
YE4-355 1-4	355	634	1490	96.7	0.88	2275	0.9	8.5	1.8	92
YE4-355 2-4	375	670	1490	96.7	0.88	2404	0.9	8.5	1.8	92

性能数据 Performance Data

380V 50Hz

型号 Type	功率 kW	额定 电流 A	转速 r/min	效率 Eff. %	功率 因数 P.F	额定 转矩 N.m	堵转转矩 额定转矩 $\frac{T_{st}}{T_N}$	堵转电流 额定电流 $\frac{I_{st}}{I_N}$	最大转矩 额定转矩 $\frac{T_{max}}{T_N}$	噪声 dB(A)
同步转速 1000 r/min										
YE4-80M1-6	0.37	1.1	940	78.0	0.68	3.76	1.9	6.0	2.1	54
YE4-80M2-6	0.55	1.5	940	80.9	0.68	5.59	1.9	6.0	2.1	54
YE4-90S-6	0.75	2.0	950	82.7	0.70	7.54	2.1	7.5	2.1	57
YE4-90L-6	1.1	2.8	950	84.5	0.70	11.1	2.1	7.5	2.1	57
YE4-100L-6	1.5	3.7	960	85.9	0.71	14.9	2.1	7.5	2.1	61
YE4-112M-6	2.2	5.4	975	87.4	0.71	21.5	2.1	7.5	2.1	65
YE4-132S-6	3	7.2	985	88.6	0.71	29.1	2.0	7.5	2.1	69
YE4-132M1-6	4	9.4	985	89.5	0.72	38.8	2.0	8.0	2.1	69
YE4-132M2-6	5.5	12.8	980	90.5	0.72	53.6	2.0	8.0	2.1	69
YE4-160M-6	7.5	16.4	980	91.3	0.76	73.1	2.0	8.0	2.1	73
YE4-160L-6	11	23.5	980	92.3	0.77	107	2.0	8.5	2.1	73
YE4-180L-6	15	30.7	990	92.9	0.80	145	2.0	8.5	2.1	73
YE4-200L1-6	18.5	37.6	990	93.4	0.80	178	2.0	8.5	2.1	73
YE4-200L2-6	22	44.0	990	93.7	0.81	212	2.0	8.5	2.1	73
YE4-225M-6	30	59.0	990	94.2	0.82	289	2.0	8.3	2.1	74
YE4-250M-6	37	71.7	990	94.5	0.83	357	2.0	8.3	2.1	76
YE4-280S-6	45	86.9	990	94.8	0.83	434	2.0	8.5	2.0	78
YE4-280M-6	55	105	990	95.1	0.84	531	2.0	8.5	2.0	78
YE4-315S-6	75	142	990	95.4	0.84	723	1.6	8.0	2.0	83
YE4-315M-6	90	168	990	95.6	0.85	868	1.6	8.0	2.0	83
YE4-315L1-6	110	205	990	95.8	0.85	1061	1.6	8.0	2.0	83
YE4-315L2-6	132	243	990	96.0	0.86	1273	1.6	8.0	2.0	83
YE4-315L3-6	160	294	990	96.2	0.86	1543	1.6	8.0	2.0	83
YE4-315L4-6	185	339	990	96.3	0.86	1785	1.6	8.0	2.0	83
YE4-355M1-6	160	294	995	96.2	0.86	1536	1.6	8.0	2.0	85
YE4-355M-6	185	339	995	96.3	0.86	1776	1.6	8.0	2.0	85
YE4-355M2-6	200	367	995	96.3	0.86	1920	1.6	8.0	2.0	85
YE4-355L1-6	220	403	995	96.4	0.86	2112	1.6	8.0	2.0	85
YE4-355L-6	250	458	995	96.5	0.86	2399	1.6	8.0	2.0	85
YE4-355 1-6	280	512	995	96.6	0.86	2687	1.6	8.0	2.0	91
YE4-355 2-6	315	604	995	96.6	0.82	3023	0.9	7.9	1.8	91
同步转速 750 r/min										
YE4-80M1-8	0.18	0.81	705	67.2	0.50	2.44	1.8	5.2	1.9	52
YE4-80M2-8	0.25	1.07	710	70.8	0.50	3.36	1.8	5.7	1.9	52
YE4-90S-8	0.37	1.3	695	74.3	0.60	5.08	1.8	6.2	1.9	56
YE4-90L-8	0.55	1.8	695	77.0	0.61	7.56	1.8	5.9	2.0	56
YE4-100L1-8	0.75	2.2	705	78.4	0.66	10.2	2.0	7.0	2.0	59
YE4-100L2-8	1.1	3.1	705	80.8	0.67	14.9	2.0	7.0	2.0	59
YE4-112M-8	1.5	4.0	710	82.6	0.69	20.2	2.0	7.0	2.0	61
YE4-132S-8	2.2	5.7	730	84.5	0.70	28.8	1.8	7.5	2.0	64
YE4-132M-8	3	7.6	730	85.9	0.70	39.2	1.8	7.8	2.0	64
YE4-160M1-8	4	9.8	730	87.1	0.71	52.3	1.8	7.9	2.0	68
YE4-160M2-8	5.5	13.1	730	88.3	0.72	72.0	1.8	8.1	2.0	68

性能数据 Performance Data

380V 50Hz

型号 Type	功率 kW	额定 电流 A	转速 r/min	效率 Eff.%	功率 因数 P.F	额定 转矩 N.m	堵转转矩 额定转矩 $\frac{T_{st}}{T_N}$	堵转电流 额定电流 $\frac{I_{st}}{I_N}$	最大转矩 额定转矩 $\frac{T_{max}}{T_N}$	噪声 dB(A)
同步转速 750 r/min										
YE4-160L-8	7.5	17.2	730	89.3	0.74	98.1	1.8	7.8	2.0	68
YE4-180L-8	11	25.0	735	90.4	0.74	143	1.8	7.9	2.0	70
YE4-200L-8	15	33.3	735	91.2	0.75	195	1.8	8.0	2.0	73
YE4-225S-8	18.5	40.9	735	91.7	0.75	240	1.8	8.1	2.0	73
YE4-225M-8	22	47.8	735	92.1	0.76	286	1.8	8.3	2.0	73
YE4-250M-8	30	63.9	740	92.7	0.77	387	1.8	7.9	2.0	75
YE4-280S-8	37	77.4	740	93.1	0.78	478	1.8	7.9	2.0	76
YE4-280M-8	45	93.8	740	93.4	0.78	581	1.8	7.9	2.0	76
YE4-315S-8	55	111	735	93.7	0.80	700	1.6	8.2	2.0	82
YE4-315M-8	75	151	735	94.2	0.80	955	1.6	7.6	2.0	82
YE4-315L1-8	90	179	735	94.4	0.81	1146	1.6	7.7	2.0	82
YE4-315L2-8	110	218	735	94.7	0.81	1401	1.6	7.7	2.0	82
YE4-315L3-8	132	260	735	94.9	0.81	1681	1.6	7.7	2.0	82
YE4-355M1-8	132	260	740	94.9	0.81	1681	1.6	7.7	2.0	89
YE4-355M2-8	160	312	740	95.1	0.82	2037	1.6	7.7	2.0	89
YE4-355L1-8	185	360	740	95.3	0.82	2356	1.6	7.7	2.0	89
YE4-355L-8	200	388	740	95.4	0.82	2547	1.6	7.8	2.0	89
YE4-355 1-8	220	427	740	95.4	0.82	2801	1.6	7.8	2.0	89
YE4-355 2-8	250	498	740	95.4	0.80	3183	1.1	7.6	2.0	89

外形及安装尺寸 Dimensions

mm

B14 (机座无底脚、端盖上有小凸缘)

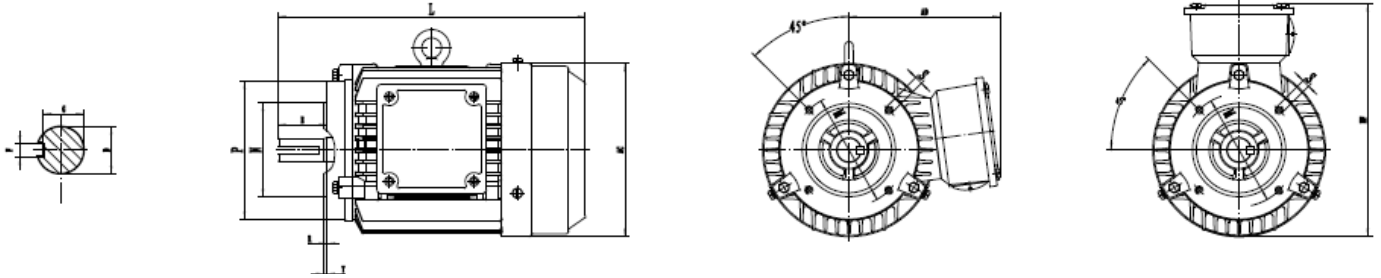

机座号 Frame	极数 Poles	安装尺寸及公差 Mounting Dimension											外形尺寸 Overall Dimension			
		D	E	F	G	M	N	P	R	S	T	AC	AD	HF	L	
80M	2,4,6,8	19	40	6	15.5	100	80	120	0	4-M6	3	165	145	225	305	
90S	2,4,6,8	24	50	8	20	115	95	140	0	4-M8	3	180	165	255	360	
90L	2,4,6,8														385	
100L	2,4,6,8	28	60	8	24	130	110	160	0	4-M8	3.5	205	175	275	445	
112M	2, 4,6,8	28	60	8	24	130	110	160	0	4-M8	3.5	225	190	300	455	

B34 (机座带底脚、端盖上有小凸缘)

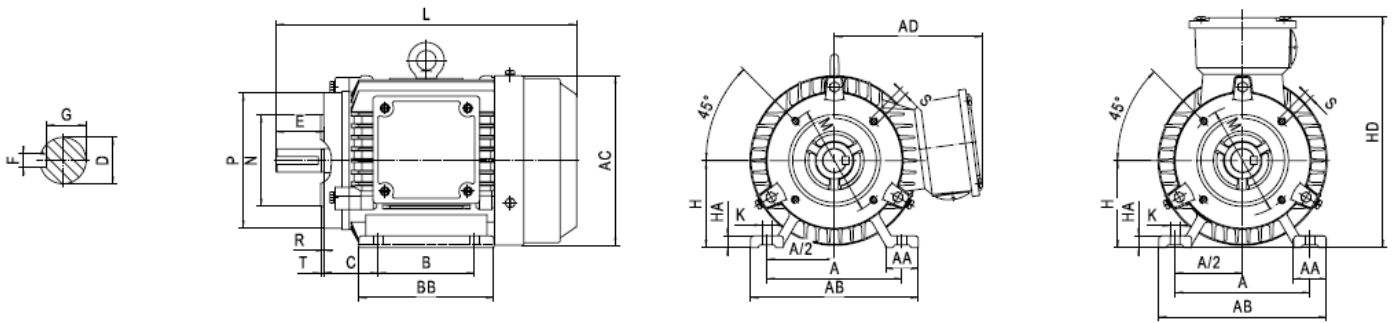

机座号 Frame	极数 Poles	安装尺寸及公差 Mounting Dimension														外形尺寸 Overall Dimension								
		A	B	C	D	E	F	G	H	K	M	N	P	R	S	T	AA	BB	HA	AB	AC	AD	HD	L
80M	2,4,6,8	125	100	50	19	40	6	15.5	80	10	100	80	120	0	4-M6	3	32	150	10	160	165	145	225	305
90S	2,4,6,8	140	100	56	24	50	8	20	90	10	115	95	140	0	4-M8	3	34	185	12	180	180	165	255	360
90L	2,4,6,8		125															210						385
100L	2,4,6,8	160	140	63	28	60	8	24	100	12	130	110	160	0	4-M8	3.5	39	238	14	200	205	175	275	445
112M	2, 4,6,8	190	140	70	28	60	8	24	112	12	130	110	160	0	4-M8	3.5	45	230	14	230	225	190	300	455

外形及安装尺寸 Dimensions

mm

B3 (机座带底脚、端盖无凸缘)

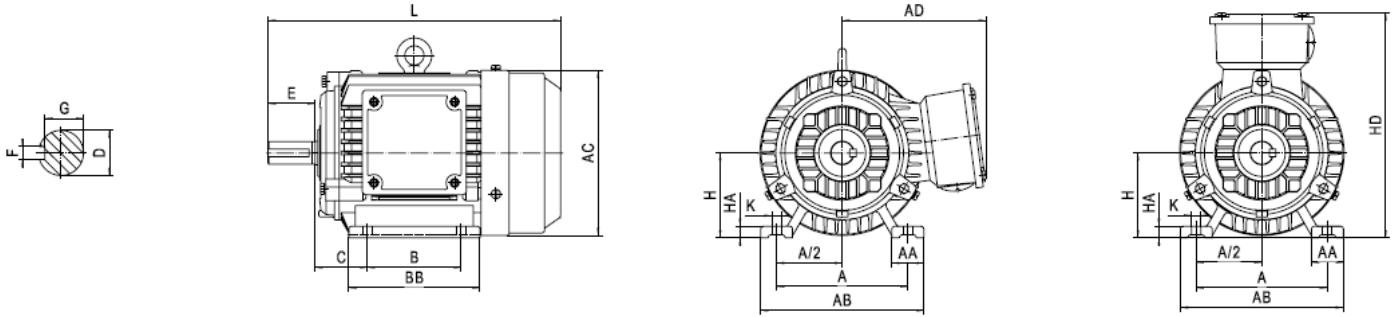

机座号 Frame	极数 Poles	安 装 尺 寸 Mounting Dimension									外 形 尺 寸 Overall Dimension												
		A	B	C	D	E	F	G	H	K	AA	BB	HA	AB	AC	AD	HD	L					
80M	2,4,6,8	125	100	50	19	40	6	155	80	10	32	150	10	160	165	145	225	305					
90S	2,4,6,8	140	100	56	24	50	8	20	90	10	34	185	12	180	180	165	255	360					
90L			125									210						385					
100L	2,4,6,8	160	140	63	28	60	8	24	100	12	40	238	14	200	205	175	275	445					
112M	2,4,6,8	190	140	70	28	60	8	24	112	12	45	230	14	230	225	190	300	455					
132S1	2	216	140	89	38	80	10	33	132	12	55	186	18	265	270	220	350	475					
132S2												224						510					
132S	4 6,8	216	140	89	38	80	10	33	132	12	55	224 186	18	265	270	220	350	510 475					
132M	2,4,6,8	216	178	89	38	80	10	33	132	12	55	224	18	265	270	220	350	510					
160M	2,4,6,8	254	210	108	42	110	12	37	160	15	67	304	20	320	320	260	420	655					
160L			254									334						685					
180M	2,4,6,8	279	241	121	48	110	14	425	180	15	72	331	22	350	375	265	445	705					
180L			279									369						745					
200L	2,4,6,8	318	305	133	55	110	16	49	200	19	75	425	26	400	400	305	505	835					
225S	4	356	286	149	60	140	18	53	225	19	79	428	28	437	450	325	550	870					
225M	2		311		55	110	16	49				453						870					
	4,6,8		311		60	140	18	53				900											
250M	2 4,6,8	406	349	168	60 65	140	18	53 58	250	24	80	445	30	490	510	380	630	890					
280S	2 4,6,8	457	368	190	65 75	140	18 20	58 67.5	280	24	90	485	35	545	550	395	675	975					
280M	2																	419	65 75	18 20	58 67.5	536	1025
	4,6,8																						419
315S	2 4,6,8	508	406	216	65 80	140 170	18 22	58 71	315	28	120	570	45	635	630	540	855	1180 1210					
315M	2																	457	65 80	140 170	18 22	58 71	680
	4,6,8	457	65 80	140 170	18 22	58 71	680																
315L	2 4,6,8	508	508	216	65 80	140 170	18 22	58 71	315	28	120	680	45	635	630	540	855	1290 1320					
315L2	6,8	508	508	216	80	170	22	71										1420					
315L3	2	508	508	216	65	140	18	58	315	28	120	680	45	635	630	540	855	1390					
	4,6,8				80	170	22	71										1420					
355M	2 4,6,8	610	560	254	75	140	20	67.5	355	28	130	690	52	735	715	645	1000	1390 1420					
	2				630	75	140	20										67.5	750	1500			
355LL1	4,6,8	630	75	140					20	67.5	1530												
355 1/	2	630	630	254	80	170	22	71	355	28	130	750	52	735	715	645	1000	1530					
355 2	4,6,8				110	210	28	100										1570					

外形及安装尺寸 Dimensions

mm

B5 (机座不带底脚、端盖有凸缘)

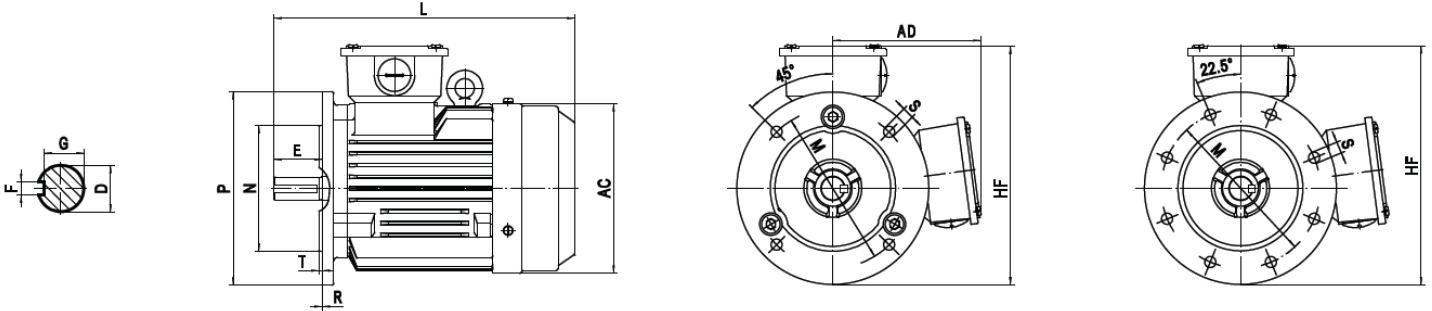

H80-200mm

H225-280mm

机座号 Frame	极数 Poles	安 装 尺 寸 及 公 差 Mounting Dimension										外 形 尺 寸 Overall Dimension			
		D	E	F	G	M	N	P	R	S	T	AC	AD	HF	L
80M	2,4,6,8	19	40	6	15.5	165	130	200	0	4-Φ12	3.5	165	145	245	305
90S	2,4,6,8	24	50	8	20	165	130	200	0	4-Φ12	3.5	180	165	265	360
90L															385
100L	2,4,6,8	28	60	8	24	215	180	250	0	4-Φ15	4	205	175	300	445
112M	2,4,6,8	28	60	8	24	215	180	250	0	4-Φ15	4	225	190	315	455
132S1	2	38	80	10	33	265	230	300	0	4-Φ15	4	270	220	370	475
132S2															510
132S	4 6,8	38	80	10	33	265	230	300	0	4-Φ15	4	270	220	370	510
															475
132M	2,4,6,8	38	80	10	33	265	230	300	0	4-Φ15	4	270	220	370	510
160M	2,4,6,8	42	110	12	37	300	250	350	0	4-Φ19	5	320	260	435	655
160L															685
180M	2,4,6,8	48	110	14	42.5	300	250	350	0	4-Φ19	5	375	265	440	705
180L															745
200L	2,4,6,8	55	110	16	49	350	300	400	0	4-Φ19	5	400	305	505	835
225S	4	60	140	18	53	400	350	450	0	8-Φ19	5	450	325	550	870
225M	2	55	110	16	49										870
	4,6,8	60	140	18	53										900
250M	2	60	140	18	53	500	450	550	0	8-Φ19	5	510	380	655	890
	4,6,8	65			58										
280S	2	65	140		18	500	450	550	0	8-Φ19	5	550	395	670	975
	4,6,8	75			20										
280M	2	65													
	4,6,8	75	20	67.5											

外形及安装尺 Dimensions

mm

B35 (机座带底脚、端盖有凸缘)

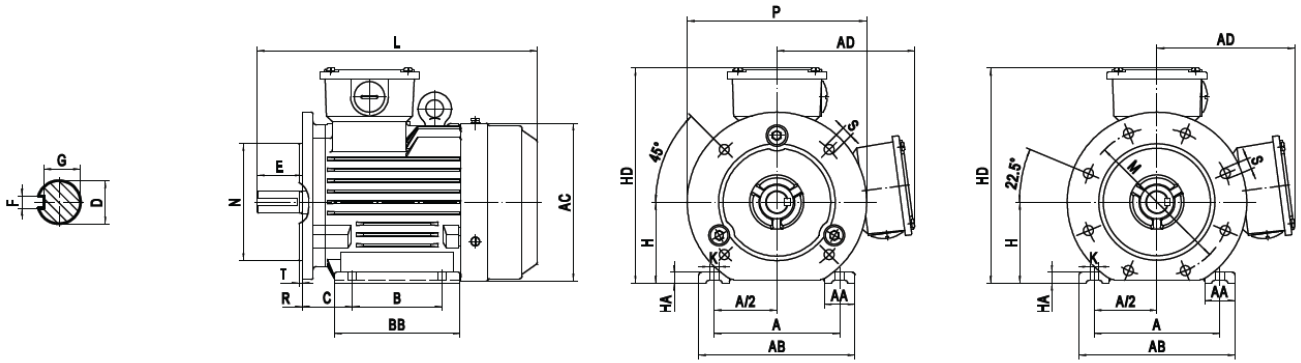

H80-200mm

H225-355mm

机座号 Frame	极数 Poles	安 装 尺 寸 及 公 差 Mouting Dimension														外 形 尺 寸 Overall Dimension									
		A	B	C	D	E	F	G	H	K	M	N	P	R	S	T	AA	BB	HA	AB	AC	AD	HD	L	
80M	2,4,6,8	125	100	50	19	40	6	15.5	80	10	165	130	200	0	4-Φ12	3.5	32	150	10	160	165	145	225	305	
90S	2,4,6,8	140	100	56	24	50	8	20	90	10	165	130	200	0	4-Φ12	3.5	34	185	12	180	180	165	255	360	
90L			210															385							
100L	2,4,6,8	160	140	63	28	60	8	24	100	12	215	180	250	0	4-Φ15	4	40	238	14	200	205	175	275	445	
112M	2,4,6,8	190	140	70	28	60	8	24	112	12	215	180	250	0	4-Φ15	4	45	230		230	225	190	300	455	
132S1	2	216	140	89	38	80	10	33	132	12	265	230	300	0	4-Φ15	4	55	186	18	265	270	220	350	475	
132S2																		224						510	
132S	4	216	140	89	38	80	10	33	132	12	265	230	300	0	4-Φ15	4	55	224	18	265	270	220	350	510	
	6,8																	186						475	
132M	2,4,6,8	216	178	89	38	80	10	33	132	12	265	230	300	0	4-Φ15	4	55	224	18	265	270	220	350	510	
160M	2,4,6,8	254	210	108	42	110	12	37	160	15	300	250	350	0	4-Φ19	5	67	304	20	320	320	260	420	655	
160L			254															334						685	
180M	2,4,6,8	279	241	121	48	110	14	42.5	180	15	300	250	350	0	4-Φ19	5	72	331	22	350	375	265	445	705	
180L			279															369						745	
200L	2,4,6,8	318	305	133	55	110	16	49	200	19	350	300	400	0	4-Φ19	5	75	425	26	400	400	305	505	835	
225S	4	356	286	149	60	140	18	53	225	19	400	350	450	0	8-Φ19	5	79	428	28	437	450	325	550	870	
225M	2		311															55						110	16
	4,6,8				60	140		53																900	
250M	2	406	349	168	60	140	18	58	250	24	500	450	550	0	8-Φ19	5	80	445	30	490	510	380	630	890	
	4,6,8				65													58							445
280S	2	457	368	190	65	140	20	67.5	280	24	500	450	550	0	8-Φ19	5	90	485	35	545	550	395	675	975	
280M	4,6,8				419													65							18
	2				75		20	67.5																	
315S	2	508	406	216	65	140	18	58	315	28	600	550	660	0	8-Φ24	6	120	570	45	630	630	540	855	1180	
	4,6,8				80	170	22	71										610						1290	
315M	2	508	457	216	65	140	18	58	315	28	600	550	660	0	8-Φ24	6	120	610	45	630	630	540	855	1290	
	4,6,8				80	170	22	71										680						1420	
315L	2	508	457	216	65	140	18	58	315	28	600	550	660	0	8-Φ24	6	120	610	45	630	630	540	855	1290	
	4,6,8				80	170	22	71										680						1320	
315L2	6,8				80	170	22	71										680						1420	
315L3	2	508	457	216	65	140	20	58	315	28	600	550	660	0	8-Φ24	6	120	610	45	630	630	540	855	1390	
	4,6,8				80	170	25	71										680						1420	
355M	2	610	560	254	75	140	20	67.5	355	28	740	680	800	0	8-Φ24	6	130	690	52	730	715	645	1000	1390	
	4,6,8				95	170	25	86										750						1420	
355L1	2	610	560	254	75	140	20	67.5	355	28	740	680	800	0	8-Φ24	6	130	690	52	730	715	645	1000	1500	
	4,6,8				95	170	25	86										750						1530	
355 1	2	610	560	254	80	170	22	71	355	28	740	680	800	0	8-Φ24	6	130	750	52	730	715	645	1000	1530	
355 2	4,6,8				110	210	28	100										750						1570	

外形及安装尺寸 Dimensions

mm

V1 (立式安装、机座不带底脚、端盖有凸缘、轴伸向下的电动机)

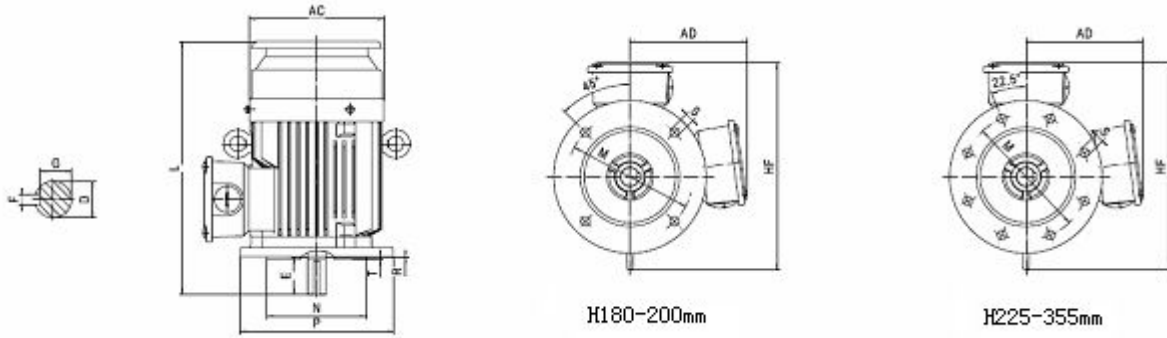

机座号 Frame	极数 Poles	安 装 尺 寸 Mounting Dimension										外形尺寸 Overall Dimension												
		D	E	F	G	M	N	P	R	S	T	AC	AD	HF	L									
180M	2,4,6	48	110	14	42.5	300	250	350	0	4-Φ19	5	375	265	500	755									
180L															795									
200L	2,4,6	55	110	16	49	350	300	400	0	4-Φ19	5	400	305	570	890									
225S	4	60	140	18	53	400	350	450	0	8-Φ19	5	450	325	615	930									
225M	2	55	110	16	49										930									
	4,6	60	140	18	53										960									
250M	2	60	140	18	53	500	450	550	0	8-Φ19	5	510	380	715	955									
	4,6	65			58																			
280S	2	65	140	18	58	500	450	550	0	8-Φ19	5	550	395	760	1050									
	4,6	75		20	67.5																			
280M	2	65		18	58										1100									
	4,6	75		20	67.5																			
315S	2	65	140	18	58	600	550	660	0	8-Φ24	6	630	540	970	1310									
	4,6	80	170	22	71										1340									
315M	2	65	140	18	58										1420									
	4,6	80	170	22	71										1450									
315L	2	65	140	18	58										1420									
	4,6	80	170	22	71										1450									
315L2	6,8														1550									
315L3	2	65	140	18	58										1520									
	4,6,8	80	170	22	71										1550									
355M	2	75	140	20	67.5										740	680	800	0	8-Φ24	6	715	645	1135	1530
	4,6	95	170	25	86																			1560
355L/L1	2	75	140	20	67.5																			1640
	4,6	95	170	25	86	1670																		
355 1/	2	80	170	22	71	1670																		
355 2	4,6	110	210	28	100	1710																		

★注：1. V1 安装型式 H80-160 的电机外形图和尺寸参见同型号 B5 电机相关图纸和数据。

2. 安装尺寸偏差按技术条件规定，外形尺寸因铸件批次稍有差异，以上外形图及尺寸仅供客户参考选型。

常用的安装结构型式，以及适用的机座号见下表：

Conventional mounting type and suitable frame size are given in following table (with “√”)

机座号 Frame	基本安装结构 basic type			派生的安装形式 derived type											
	B3	B5	B35	V1	V3	V5	V6	B6	B7	B8	V15	V36	B14	B34	V18
63~112	√	√	√	√	√	√	√	√	√	√	√	√	√	√	√
132~160	√	√	√	√	√	√	√	√	√	√	√	√	-	-	-
180~280	√	√	√	√	-	-	-	-	-	-	-	-	-	-	-
315~355	√	-	√	√	-	-	-	-	-	-	-	-	-	-	-

注：“√”表示可以制造生产的结构型式，电机订购时，若不作说明的接线盒为侧式右出线。以上数据，如有变更，恕不另行通知。

If there is no other request in the order or agreement, terminal box position at the right side of the frame is regarded as standard; data above may be changed without prior notice.