

YE3L 系列铝机壳三相异步电动机

YE3L Series Aluminum Frame Three Phase Induction Motors

一、概述



机座号 80~160 **功率 0.37~18.5kW**
工作制 S1 **冷却方式: IC411**
能效等级: 中国 GB18613-2020 3 级 (IE3)

适用于: 一般场所和无特殊要求的机械, 如金属切削机床、泵、风机、运输机械、搅拌机、农业机械、食品机械等。

Applications: General purpose including cutting machines, pumps, fans, conveyors, machines tools of farm duty and food process.

特点: 外形美观、高效节能, F 级绝缘, 防护等级为 IP55, 噪声低、振动小, 运行可靠。

Features: Beautiful profile, high efficiency and energy saving, class F insulation, IP55 protection grade, low noise, little vibration, reliable running.

性能数据 Performance Data

380V 50Hz

型号 Type	功率 kW	额定 电流 A	转速 r/min	效率 Eff. %	功率 因数 P.F	额定 转矩 N.m	堵转转矩 额定转矩 $\frac{T_{st}}{T_N}$	堵转电流 额定电流 $\frac{I_{st}}{I_N}$	最大转矩 额定转矩 $\frac{T_{max}}{T_N}$	噪声 dB(A)
同步转速 3000 r/min										
YE3-63M1-2	0.18	0.52	2720	65.9	0.80	0.63	2.3	5.5	2.2	61
YE3-63M2-2	0.25	0.67	2720	69.7	0.81	0.88	2.3	5.5	2.2	61
YE3-71M1-2	0.37	0.94	2770	73.8	0.81	1.29	2.3	6.1	2.2	62
YE3-71M2-2	0.55	1.3	2795	77.8	0.82	1.92	2.3	6.1	2.2	62
YE3L80M1-2	0.75	1.7	2870	80.7	0.82	2.50	2.2	7.0	2.3	62
YE3L80M2-2	1.1	2.4	2875	82.7	0.83	3.65	2.2	7.3	2.3	62
YE3L90S-2	1.5	3.2	2880	84.2	0.84	4.97	2.2	7.6	2.3	67
YE3L90L-2	2.2	4.6	2880	85.9	0.85	7.30	2.2	7.6	2.3	67
YE3L100L-2	3	6.0	2880	87.1	0.87	9.95	2.2	7.8	2.3	74
YE3L112M-2	4	7.8	2915	88.1	0.88	13.1	2.2	8.3	2.3	77
YE3L132S1-2	5.5	10.6	2935	89.2	0.88	17.9	2.0	8.3	2.3	79
YE3L132S2-2	7.5	14.4	2930	90.1	0.88	24.4	2.0	7.9	2.3	79
YE3L160M1-2	11	20.6	2950	91.2	0.89	35.6	2.0	8.1	2.3	81
YE3L160M2-2	15	27.9	2945	91.9	0.89	48.6	2.0	8.1	2.3	81
YE3L160L-2	18.5	34.2	2945	92.4	0.89	60.0	2.0	8.2	2.3	81
同步转速 1500 r/min										
YE3-63M1-4	0.12	0.39	1325	64.8	0.72	0.86	2.1	4.4	2.2	52
YE3-63M2-4	0.18	0.54	1350	69.9	0.73	1.27	2.1	4.4	2.2	52
YE3-71M1-4	0.25	0.70	1355	73.5	0.74	1.80	2.1	5.2	2.2	55

性能数据 Performance Data

380V 50Hz

型号 Type	功率 kW	额定 电流 A	转速 r/min	效率 Eff. %	功率 因数 P.F	额定 转矩 N.m	堵转转矩 额定转矩 $\frac{T_{st}}{T_N}$	堵转电流 额定电流 $\frac{I_{st}}{I_N}$	最大转矩 额定转矩 $\frac{T_{max}}{T_N}$	噪声 dB(A)
同步转速 1500 r/min										
YE3-71M2-4	0.37	0.98	1375	77.3	0.75	2.66	2.1	5.2	2.2	55
YE3L80M1-4	0.55	1.4	1430	80.8	0.75	3.67	2.3	6.5	2.3	56
YE3L80M2-4	0.75	1.8	1430	82.5	0.75	5.01	2.3	6.6	2.3	56
YE3L90S-4	1.1	2.6	1430	84.1	0.76	7.35	2.3	6.8	2.3	59
YE3L90L-4	1.5	3.5	1430	85.3	0.77	10.0	2.3	7.0	2.3	59
YE3L100L1-4	2.2	4.8	1440	86.7	0.81	14.6	2.3	7.6	2.3	64
YE3L100L2-4	3	6.3	1440	87.7	0.82	19.9	2.3	7.6	2.3	64
YE3L112M-4	4	8.4	1455	88.6	0.82	26.3	2.2	7.8	2.3	65
YE3L132S-4	5.5	11.2	1465	89.6	0.83	35.9	2.0	7.9	2.3	71
YE3L132M-4	7.5	15.0	1465	90.4	0.84	48.9	2.0	7.5	2.3	71
YE3L160M-4	11	21.5	1470	91.4	0.85	71.5	2.2	7.7	2.3	73
YE3L160L-4	15	28.8	1470	92.1	0.86	97.4	2.2	7.8	2.3	73
同步转速 1000 r/min										
YE3-71M1-6	0.18	0.65	850	63.9	0.66	2.02	1.9	4.0	2.0	52
YE3-71M2-6	0.25	0.85	850	65.4	0.68	2.81	1.9	4.0	2.0	52
YE3L80M1-6	0.37	1.1	925	73.5	0.70	3.88	1.9	5.5	2.0	54
YE3L80M2-6	0.55	1.5	925	77.2	0.72	5.68	1.9	5.8	2.1	54
YE3L90S-6	0.75	2.0	945	78.9	0.71	7.58	2.0	6.0	2.1	57
YE3L90L-6	1.1	2.8	950	81.0	0.73	11.1	2.0	6.0	2.1	57
YE3L100L-6	1.5	3.8	950	82.5	0.73	15.1	2.0	6.5	2.1	61
YE3L112M-6	2.2	5.4	965	84.3	0.74	21.8	2.0	6.6	2.1	65
YE3L132S-6	3	7.2	975	85.6	0.74	29.4	1.9	6.8	2.1	69
YE3L132M1-6	4	9.5	975	86.8	0.74	39.2	1.9	6.8	2.1	69
YE3L132M2-6	5.5	12.7	975	88.0	0.75	53.9	2.0	7.0	2.1	69
YE3L160M-6	7.5	16.2	980	89.1	0.79	73.1	2.0	7.0	2.1	70
YE3L160L-6	11	23.1	980	90.3	0.80	107	2.0	7.2	2.1	70
同步转速 750 r/min										
YE3L80M1-8	0.18	0.76	690	58.7	0.61	2.49	1.8	3.3	1.9	52
YE3L80M2-8	0.25	0.97	690	64.1	0.61	3.46	1.8	3.3	1.9	52
YE3L90S-8	0.37	1.3	695	69.3	0.61	5.08	1.8	4.0	1.9	56
YE3L90L-8	0.55	1.9	695	73.0	0.61	7.56	1.8	4.0	2.0	56
YE3L100L1-8	0.75	2.3	705	75.0	0.67	10.2	1.8	4.0	2.0	59
YE3L100L2-8	1.1	3.1	705	77.7	0.69	14.9	1.8	5.0	2.0	59
YE3L112M-8	1.5	4.1	710	79.7	0.70	20.2	1.8	5.0	2.0	61
YE3L132S-8	2.2	5.7	725	81.9	0.71	29.0	1.8	6.0	2.2	64
YE3L132M-8	3	7.5	725	83.5	0.73	39.5	1.8	6.0	2.2	64
YE3L160M1-8	4	9.8	730	84.8	0.73	52.3	1.9	6.0	2.2	68
YE3L160M2-8	5.5	13.1	730	86.2	0.74	72.0	1.9	6.0	2.2	68
YE3L160L-8	7.5	17.4	730	87.3	0.75	98.1	1.9	6.0	2.2	68

外形及安装尺寸 Dimensions

mm

B14 (机座无底脚、端盖上有小凸缘)

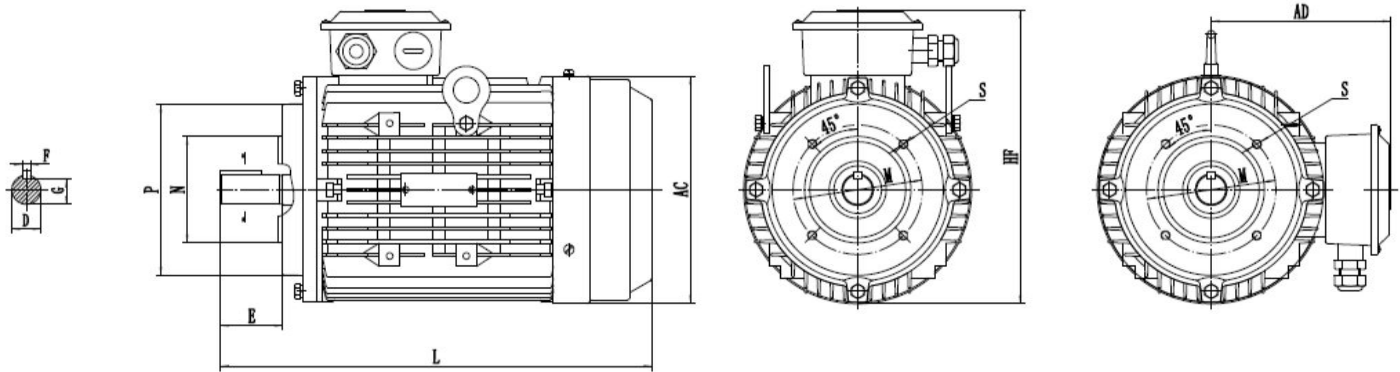

机座号 Frame	极数 Poles	安 装 尺 寸 及 公 差 Mounting Dimension										外 形 尺 寸 Overall Dimension				
		D	E	F	G	M	N	P	R	S	T	AC	AD	HF	L	
63M	2,4	11	23	4	8.5	75	60	90	0	4-M6	2.5	135	112	140	225	
71M	2,4,6	14	30	5	11	85	70	105	0	4-M6	2.5	145	120	1650	245	
80M	2,4,6,8	19	40	6	15.5	100	80	120	0	4-M6	3	165	135	225	295	
90S	2,4,6,8	24	50	8	20	115	95	140	0	4-M8	3	180	145	255	345	
90L	2,4,6,8														385	
100L	2,4,6,8	28	60	8	24	130	110	160	0	4-M8	3.5	205	155	275	390	
112M	2,6,8	28	60	8	24	130	110	160	0	4-M8	3.5	225	180	300	420	
	4														450	

B34 (机座带底脚、端盖上有小凸缘)

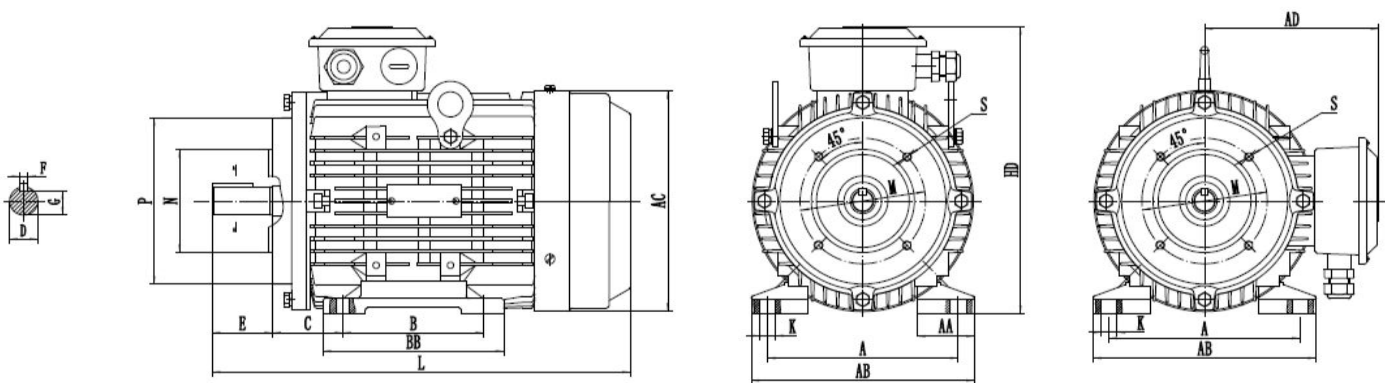

机座号 Frame	极数 Poles	安 装 尺 寸 及 公 差 Mounting Dimension														外 形 尺 寸 Overall Dimension								
		A	B	C	D	E	F	G	H	K	M	N	P	R	S	T	AA	BB	HA	AB	AC	AD	HD	L
63M	2,4	100	80	40	11	23	4	8.5	63	7X11.5	75	60	90	0	4-M5	2.5	35.5	110	8	135	135	112	175	225
71M	2,4,6	112	90	45	14	30	5	11	71	7X11.5	85	70	105	0	4-M5	2.5	36	120	8	150	145	120	190	245
80M	2,4,6,8	125	100	50	19	40	6	15.5	80	10X13	100	80	120	0	4-M6	3	35	130	10	160	165	135	215	295
90S	2,4,6,8	140	100	56	24	50	8	20	90	10X13	115	95	140	0	4-M8	3	35	130	12	175	180	145	235	345
90L	2,4,6,8		125															155						385
100L	2,4,6,8	160	140	63	28	60	8	24	100	12X16	130	110	160	0	4-M8	3.5	37	176	14	196	205	155	255	390
112M	2,6,8	190	140	70	28	60	8	24	112	12X16	130	110	160	0	4-M8	3.5	44	180	14	216	225	180	290	420
	4																							450

外形及安装尺寸 Dimensions
B3 (机座带底脚、端盖无凸缘)

mm

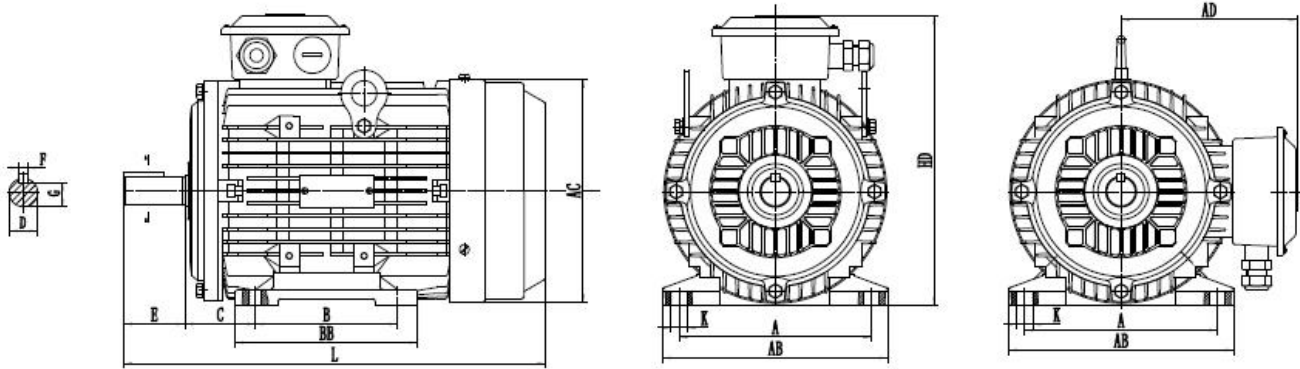

机座号 Frame	极数 Poles	安 装 尺 寸 Mounting Dimension										外 形 尺 寸 Overall Dimension			
		A	B	C	D	E	F	G	H	K	BB	HA	AB	HD	L
63M	2,4	100	80	40	11	23	4	8.5	63	7X11.5	105	8	125	175	225
71M	2,4,6	112	90	45	14	30	5	11	71	7X11.5	116	8	136	190	245
80M	2,4,6,8	125	100	50	19	40	6	15.5	80	10X13	130	10	160	215	295
90S	2,4,6,8	140	100	56	24	50	8	20	90	10X13	130	12	175	235	345
90L			125								155				385
100L	2,4,6,8	160	140	63	28	60	8	24	100	12X16	176	14	196	255	390
112M	2,6,8	190	140	70	28	60	8	24	112	12X16	180	14	216	290	420
	4														450
132S	2,4,6,8	216	140	89	38	80	10	33	132	12X16	186	16	260	335	465
132M			178								224				505
160M	2,4,6,8	254	210	108	42	110	12	37	160	15X19	260	20	309	400	605
160L			254								304				650

B5 (机座不带底脚、端盖有凸缘)

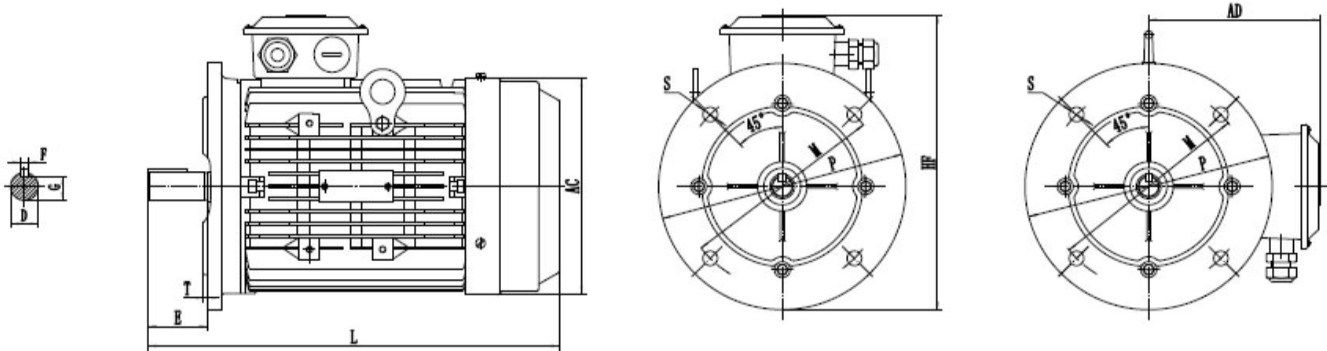

机座号 Frame	极数 Poles	安 装 尺 寸 及 公 差 Mounting Dimension										外 形 尺 寸 Overall Dimension			
		D	E	F	G	M	N	P	R	S	T	AC	AD	HF	L
63M	2,4	11	23	4	8.5	75	60	90	0	4-M6	3	135	112	140	225
71M	2,4,6	14	30	5	11	85	70	105	0	4-M6	3.5	145	120	160	245
80M	2,4,6,8	19	40	6	15.5	165	130	200	0	4-Φ12	3.5	165	135	245	295
90S	2,4,6,8	24	50	8	20	165	130	200	0	4-Φ12	3.5	180	145	265	345
90L															385
100L	2,4,6,8	28	60	8	24	215	180	250	0	4-Φ15	4	205	155	300	390
112M	2,6,8	28	60	8	24	215	180	250	0	4-Φ15	4	225	180	315	420
	4														450
132S	2,4,6,8	38	80	10	33	265	230	300	0	4-Φ15	4	270	205	370	465
132M															505
160M	2,4,6,8	42	110	12	37	300	250	350	0	4-Φ19	5	325	240	435	605
160L															650

外形及安装尺寸 Dimensions
B35 (机座带底脚、端盖有凸缘)

mm

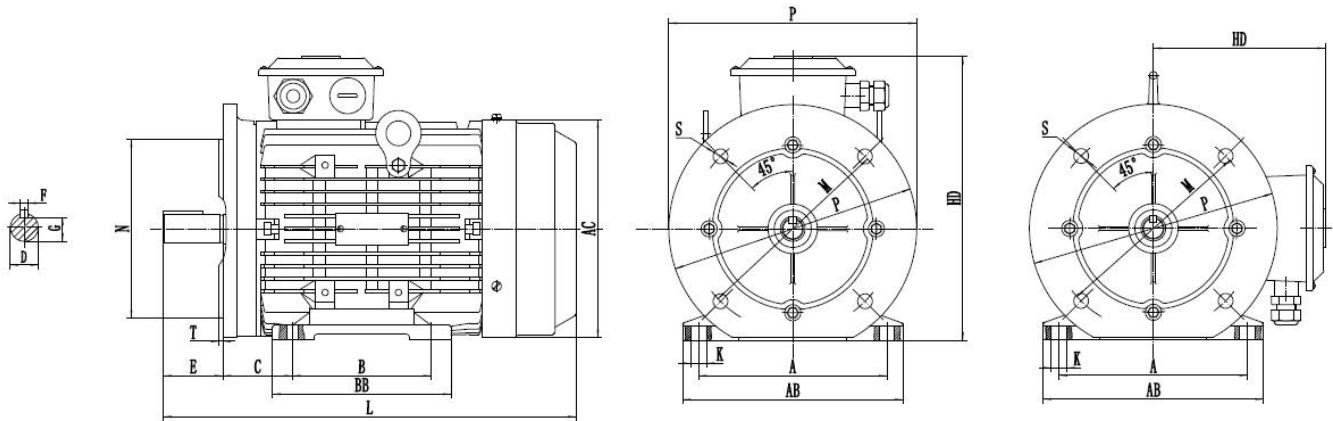

机座号 Frame	极数 Poles	安 装 尺 寸 及 公 差 Mounting Dimension														外 形 尺 寸 Overall Dimension									
		A	B	C	D	E	F	G	H	K	M	N	P	R	S	T	AA	BB	HA	AB	AC	AD	HD	L	
63M	2,4	100	80	40	11	23	4	8.5	63	7X11.5	115	95	140	0	4-Φ10	3	35.5	105	8	125	135	112	175	225	
71M	2,4,6	112	90	45	14	30	5	11	71	7X11.5	130	110	160	0	4-Φ10	3.5	36	116	8	136	145	120	190	245	
80M	2,4,6,8	125	100	50	19	40	6	15.5	80	10X13	165	130	200	0	4-Φ12	3.5	35	130	10	160	165	135	215	295	
90S	2,4,6,8	140	100	56	24	50	8	20	90	10X13	165	130	200	0	4-Φ12	3.5	35	130	12	175	180	145	235	345	
90L			125															155						385	
100L	2,4,6,8	160	140	63	28	60	8	24	100	12X16	215	180	250	0	4-Φ15	4	37	176	14	196	205	155	255	390	
112M	2,6,8	190	140	70	28	60	8	24	112	12X16	215	180	250	0	4-Φ15	4	44	180	14	216	225	180	290	420	
	4																							450	
132S	2,4,6,8	216	140	89	38	80	10	33	132	12X16	265	230	300	0	4-Φ15	4	45	186	16	260	270	205	335	465	
132M			178															224						505	
160M	2,4,6,8	254	210	108	42	110	12	37	160	15X19	300	250	350	0	4-Φ19	5	62	260	20	309	325	240	400	605	
160L			254															304						650	

常用的安装结构型式，以及适用的机座号见下表：

Conventional mounting type and suitable frame size are given in following table (with “√”)

机座号 Frame	基本安装结构 basic type			派生的安装形式 derived type											
	B3	B5	B35	V1	V3	V5	V6	B6	B7	B8	V15	V36	B14	B34	V18
63~112	√	√	√	√	√	√	√	√	√	√	√	√	√	√	√
132~160	√	√	√	√	√	√	√	√	√	√	√	√	-	-	-
180~280	√	√	√	√	-	-	-	-	-	-	-	-	-	-	-
315~355	√	-	√	√	-	-	-	-	-	-	-	-	-	-	-

注：“√”表示可以制造生产的结构型式，电机订购时，若不作说明的接线盒为侧式右出线。以上数据，如有变更，恕不另行通知。

If there is no other request in the order or agreement, terminal box standard position is at the right side of the frame; data above may be changed without prior notice.