

JXQ (D) 系列蓄电池用交流电机

JXQ(D) Series AC Motor for Storage Battery

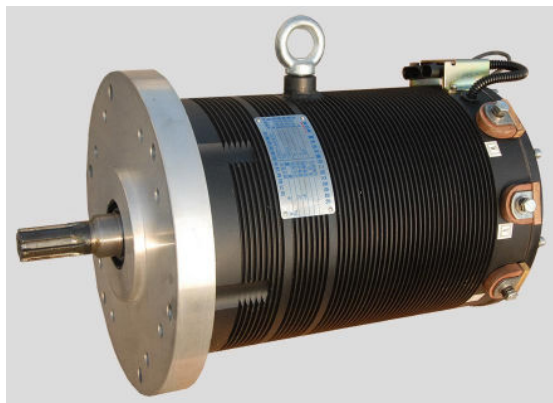

功 率 0.75~100kW

电 压 22~500V

工作制 S2、S1

绝缘等级 F

适用于: 由蓄电池供电的牵引行走的驱动和转向及提升油泵的驱动, 适用于各类电动叉车、电动轿车、电动大巴的驱动动力。

Application: Ideal for the electric forklift, electric vehicle, electric bus or oil pump and such equipment which is driven by battery.

特点: 适用面广, 可与德国 DMC、美国 DANAHER、萨牌、KDS、GE 等多种进口知名电控配套使用, 具有完备的速度反馈系统和温度检测保护系统, 本产品噪音低, 效率高, 过转矩能力强, 结构紧凑, 能在相对湿度直到 100%, 在电机表面形成凝露的环境下正常运行, 免除直流电机对电刷定期更换、整流子维护保养的烦恼, 真正实现了全过程免维护运行。

运行, 免除直流电机对电刷定期更换、整流子维护保养的烦恼, 真正实现了全过程免维护运行。

Feature: With complete speed feedback and temperature detection protection system, the motor will match with various electronic control system like DMC、DANAHER、KDS、GE etc; low noise, high efficiency, large over-torque, compact structure; can work in the environment whose relative humid is 100% or the environment by which condensation will form on the motor surface; needn't replace brush or commutator which is need to replace regularly by general DC motor.

型号意义: Designations of the type

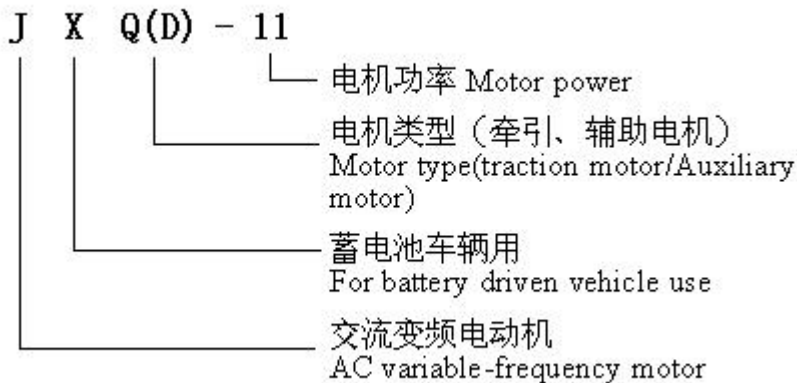

性能数据 Performance Data 蓄电池用交流牵引、辅助电动机 Battery-used traction motor、auxiliary motor

序号	型号 Type	额定 功率 (kW)	额定 电压 (V)	额定 电流 (A)	基准 频率 (Hz)	额定 转速 (r/min)	电池 电压 (V)	工作制 Duty mode	功能适用 Application
1	JXQ-0.75	0.75	17	46	75	2040	24	S2-60min	托盘搬运车 Tray truck
2	JXQ-1.1	1.1	17	65	75	2060	24	S2-60min	托盘搬运车 Tray truck
3	JXQ-1.5	1.5	17	83	75	2080	24	S2-60min	托盘搬运车 Tray truck
4	JXQ-1.5-1	1.5	25	56	75	2080	36	S2-60min	托盘搬运车、电动搬运车 Tray truck、E-pallet truck

性能数据 Performance Data 蓄电池用交流牵引、辅助电动机 Battery-used traction motor、auxiliary motor

5	JXQ-2.2	2.2	25	78.5	60	1700	36	S2-60min	托盘搬运车、电动搬运车 Tray truck、E-pallet truck
6	JXQ-2.2	2.2	33	60	60	1700	48	S2-60min	堆垛车、电动搬运车 Stacker lorry、E-pallet truck
7	JXQ-3	3	33	78	60	1700	48	S2-60min	堆垛车、电动搬运车 Stacker lorry、E-pallet truck
8	JXQ-4	4	33	105	75	2120	48	S2-60min	电动搬运车、电动叉车 E-pallet truck、E-forklift

蓄电池用交流牵引、辅助电动机 Battery-used traction motor、auxiliary motor

序号	型号 Type	额定 功率 (kW)	额定 电压 (V)	额定 电流 (A)	基准 频率 (Hz)	额定 转速 (r/min)	电池 电压 (V)	工作制 Duty mode	功能适用 Application
9	JXQ-4.5	4.5	28	134	90	2620	48	S2-60min	三支点前双驱 3-wheel front 2-drive
10	JXQ-5	5	33	124	65	1850	48	S2-60min	电动搬运车 E-pallet truck
11	JXQ-6.3	6.3	33	154	60	1720	48	S2-60min	电动搬运车、三支点前双驱 E-pallet truck、3-wheel front 2-drive
12	JXQ-7.5	7.5	33	180	60	1720	48	S2-60min	三支点前双驱 3-wheel front 2-drive
13	JXQ-8	8	33	192	44	1250	48	S2-60min	1.5T 叉车行走 1.5T forklift
14	JXQ-10	10	33	240	65	1860	48	S2-60min	电动牵引车、电动轿车 E-tractor、E-vehicle
15	JXQ-11	11	34	256	42	1330	48	S2-60min	2T 叉车行走 2T forklift
16	JXQ-16.6	16.6	52	250	55	1550	80	S2-60min	3T 叉车行走、电动牵引车 3T forklift、E-tractor
17	JXQ-18.5	18.5	52	265	75	2130	80	S2-60min	电动牵引车、电动轿车 E-tractor、E-vehicle
18	JXQ-22	22	52	310	65	1860	80	S2-60min	电动牵引车、电动轿车 E-tractor、E-vehicle
19	JXQ-30	30	52	425	60	1710	80	S2-60min	电动轿车 E-vehicle
20	JXQ-55	55	380	105	75	2200	500	S1	电动中巴、电动轿车 E-medium bus、E-vehicle
21	JXQ-75	75	380	145	75	2200	500	S1	电动中巴、城市公交车 E-medium bus、City bus
22	JXQ-100	100	380	185	65	1920	500	S1	电动大巴、城市公交车 E-bus、City bus
23	JXQD-7.8	7.8	31	200	69	1970	48	S3-15%	1.5T 叉车油泵电机 1.5T forklift、Oil pump
24	JXQD-10	10	31	255	75	2153	48	S3-15%	1.5T 叉车油泵电机 1.5T forklift、Oil pump
25	JXQD-12	12	31	278	75	2153	48	S3-15%	2T 叉车油泵电机 2T forklift、Oil pump
26	JXQD-13.5	13.5	43	250	60	1765	80	S3-15%	3T 叉车油泵电机 3T forklift、Oil pump

外形及安装尺寸 Dimensions

mm

1~1.5T 叉车交流电机牵引电机 Traction AC motor for 1~1.5T forklift

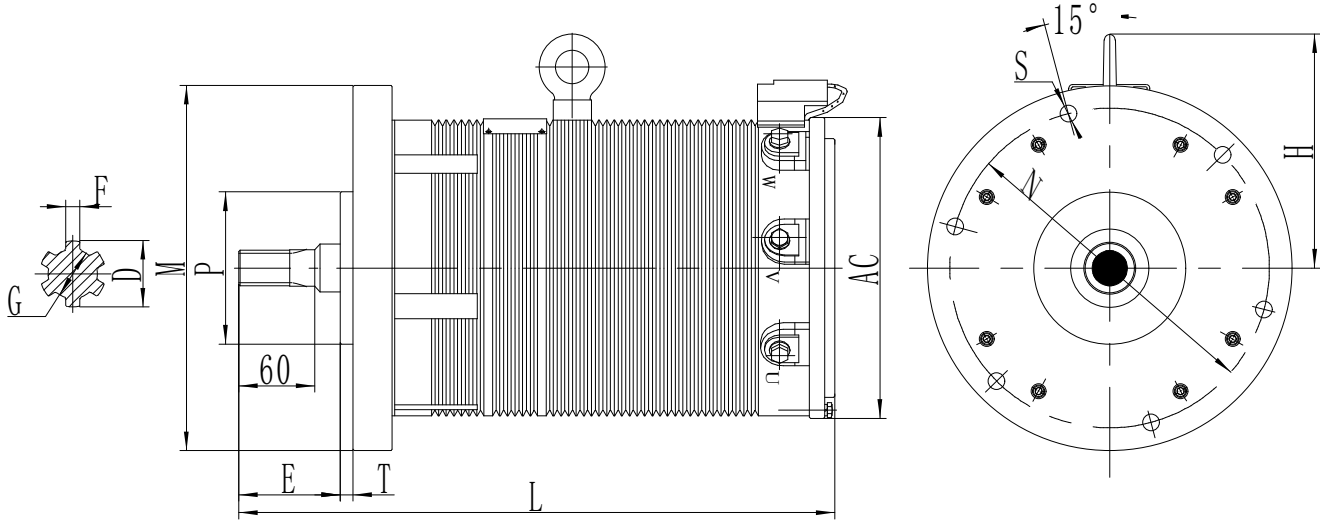

型号 Type	安装尺寸 Mounting Dimension									外形尺寸 Overall Dimension		
	T	E	D	F	G	M	P	N	S	H	AC	L
JXQ-8	10	90	28	6	23	288	120	252	Φ13.2	185	233	470

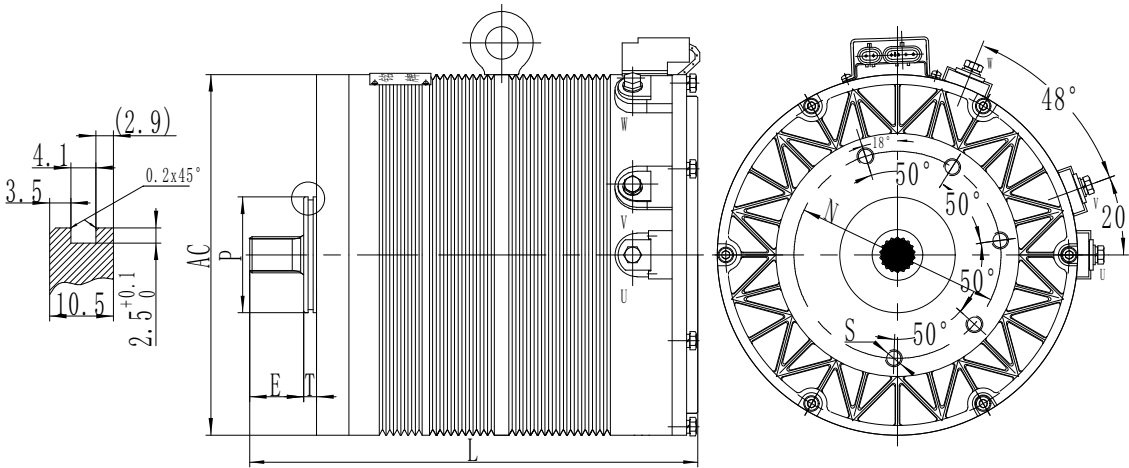

输出轴技术参数 (GB2363-80) 30×18×1.5 (IBJSD2001)	
模数 m	1.5 (mm)
齿形角 (压力角) α	20°
齿数 Za	18齿
分度圆直径 d	Φ27 (mm)
径向变位系数 X	+0.8
跨测齿数 R	3齿
公法线长度 W	12.27 ^{+0.062} / _{-0.118} mm
检测跨距 M 值	32.62 ^{+0.132} / _{-0.223} mm
检测跨棒直径	Φ2.7 mm
齿表面感应淬火硬度	HRC: 55~62
两齿轮中心重合	圆柱平行齿轮
精度等级 (JB179-81)	7-CI级

型号 Type	安装尺寸 Mounting Dimension					外形尺寸 Overall Dimension		
	T	E	P	N	S	H	AC	L
JXQ-11	10.5	55	95	170	M14X1.5	220	296	368

3~3.5T 叉车交流牵引电机 Traction AC motor for 3~3.5T forklift

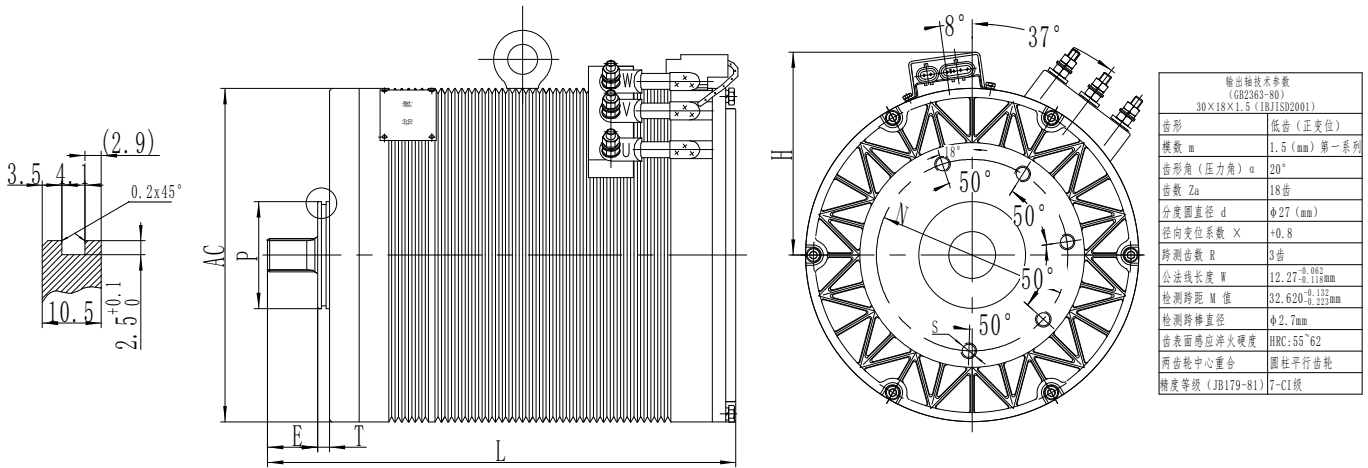

型号 Type	安装尺寸 Mounting Dimension					外形尺寸 Overall Dimension		
	T	E	P	N	S	H	AC	L
JXQ-16.6	10.5	55	95	170	M14X1.5	220	296	416

1~2.5T 叉车交流辅助电机

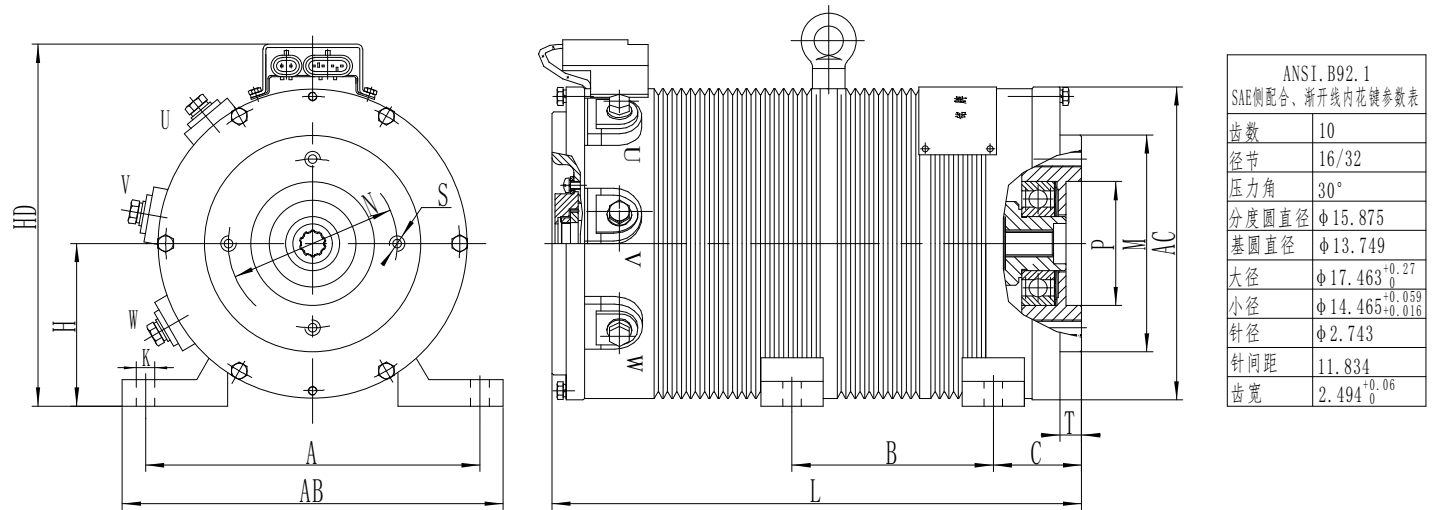

型号 Type	安装尺寸 Mounting Dimension										外形尺寸 Overall Dimension			
	T	M	P	A	B	C	H	N	K	S	HD	AB	AC	L
JXQD-10	14	140	80	216	130	57	125	109	φ12	M10	277	246	208	342
JXQD-12	14	140	80	216	110	93	125	109	φ12	M10	277	246	208	387

3~3.5T 叉车交流辅助电机

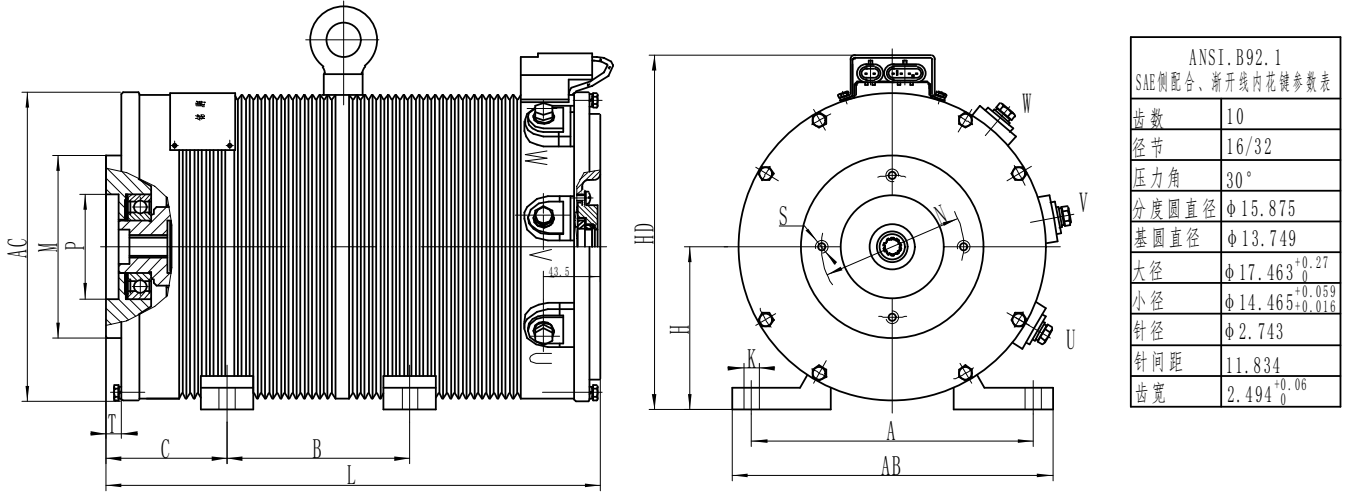

型号 Type	安装尺寸 Mounting Dimension										外形尺寸 Overall Dimension			
	A	B	C	T	M	P	H	N	K	S	AB	AC	HD	L
JXQD-13.5	216	140	93	12	140	80	125	109	φ12	M10×1.25	246	237	310	378

❖ 注: 表中外形尺寸为参考值, 实际情况以实物为准; 数据若有改动, 恕不另行通知。

Dimensions here are indicative only. Actual product may differ. Data above may be changed without prior notice.