

YL 系列双值电容异步电动机

YL Series Two-value Capacitor Induction Motors

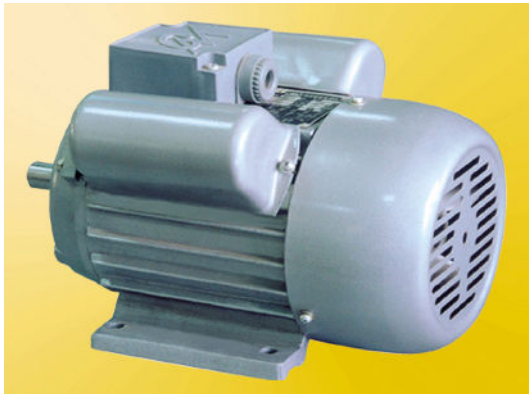

机座号 71~100

功率 0.25~3kW

防护等级 IP44

绝缘等级 B

适用于：空气压缩机、医疗器械、磨浆机等机械

Applications: Air compressors, medical instruments and small machine tools, etc.

特点: 起动性能好, 运行平稳, 通用性强

Features: Out-standing performance of starting and operation, low noise, compact dimensions and smooth running.

额定电压: 220V

Rated Voltage: 220V

技术参数 Performance Data

220V 50Hz

型号 Type	功率 kW	额定电流 Current A	转速 r/min	效率 Eff. %	功率 因数 P.F	堵转转矩 额定转矩 $\frac{T_{st}}{T_N}$	堵转电流 Ist
同步转速 3000r/min							
YL713-2	0.75	4.7	2800	72	0.92	1.8	29
YL801-2	0.75	4.9	2800	72	0.92	1.8	29
YL802-2	1.1	7.0	2800	75	0.95	1.8	40
YL90S-2	1.5	9.4	2800	76	0.95	1.7	55
YL90L-2	2.2	13.7	2800	77	0.95	1.7	80
YL100L1-2	3	18.2	2800	79	0.95	1.7	110
同步转速 1500r/min							
YL801-4	0.55	4.0	1400	68	0.92	1.8	21
YL802-4	0.75	5.1	1400	71	0.92	1.8	29
YL90S-4	1.1	7.3	1400	73	0.95	1.7	40
YL90L-4	1.5	9.7	1400	75	0.95	1.7	55
YL100L1-4	2.2	13.9	1400	76	0.95	1.7	80
YL100L2-4	3	18.6	1400	77	0.95	1.7	110
同步转速 1000r/min							
YL902-6	0.75	5.3	930	68	0.92	1.8	110
YL903-6	1.1	7.55	920	68	0.92	1.8	110
同步转速 3000r/min							
YL711-2J	0.37	2.7	2800	67	0.92	1.8	16
YL712-2J	0.55	3.9	2800	70	0.92	1.8	21
YL713-2J	0.75	4.7	2800	72	0.92	1.8	29
YL714-2J	1.1	7.0	2800	75	0.95	1.8	40
同步转速 1500r/min							
YL711-4J	0.25	2.0	1400	62	0.92	1.8	12
YL712-4J	0.37	2.8	1400	65	0.92	1.8	16
YL713-4J	0.55	4.2	1400	68	0.92	1.8	18
YL714-4J	0.75	5.1	1400	71	0.92	1.8	20

常用的安装结构型式，以及适用的机座号见下表

Conventional mounting type and suitable frame size are given in following table (with “√”)

机座号 Frame	基本安装结构 Basic Type			派生的安装形式 Derived Type								
	B3	B5	B35	V1	V3	V5	V6	V18	V19	V36	B14	B34
71~80	√	√	—	√	√	√	√	√	√	—	√	√
90	√	√	√	√	√	√	√	√	√	√	√	√
100	√	√	√	√	√	√	√	—	—	√	—	—

注：“√”表示可以制造生产的结构型式。

外形及安装尺寸 Dimensions

mm

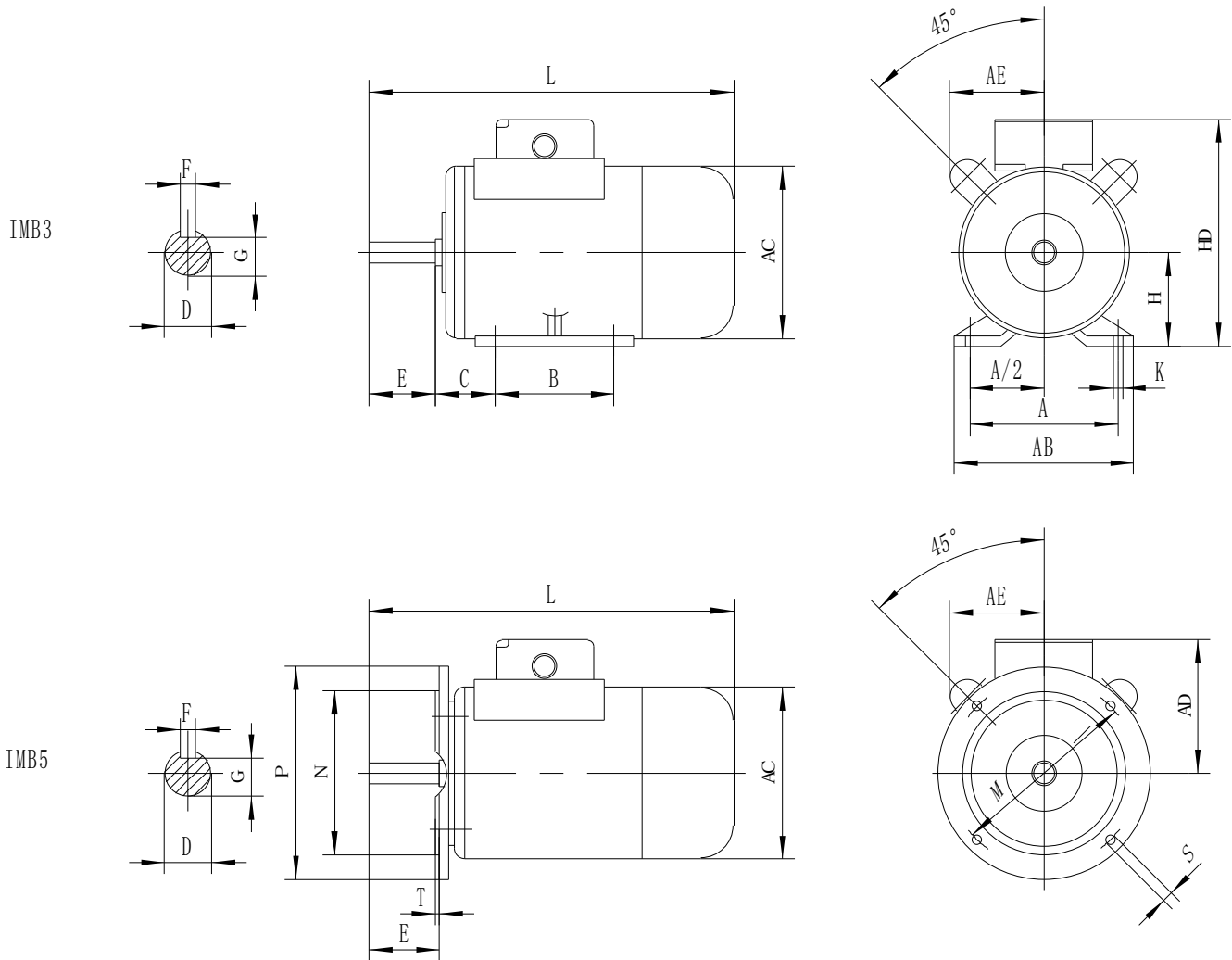

IMB35

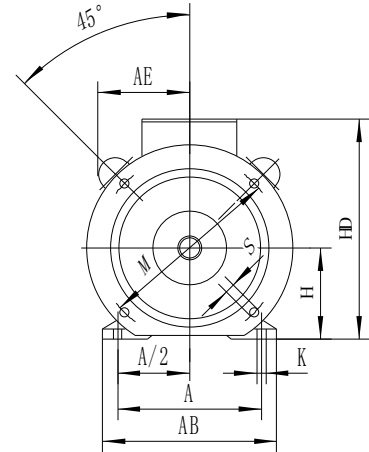
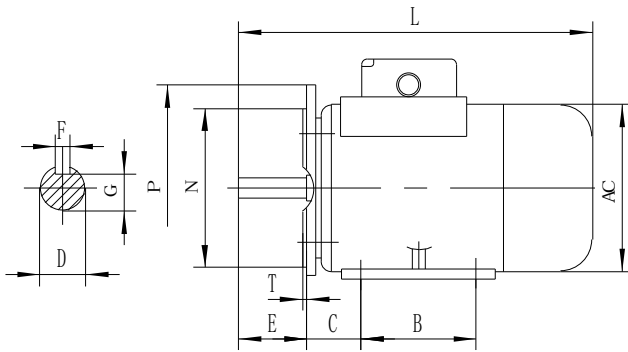

IMB14

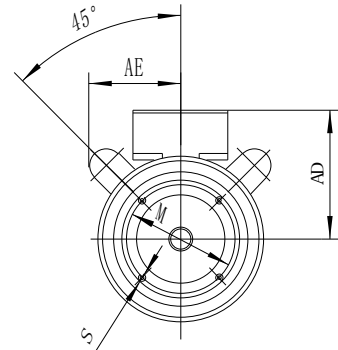
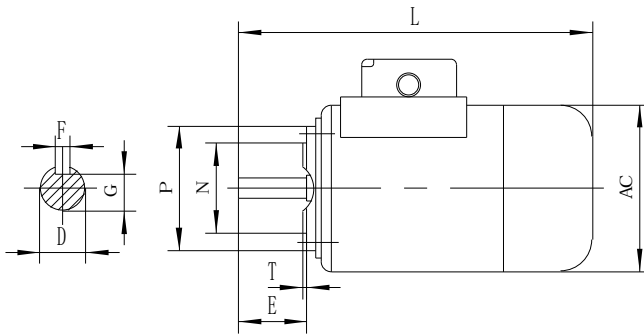

IMB34

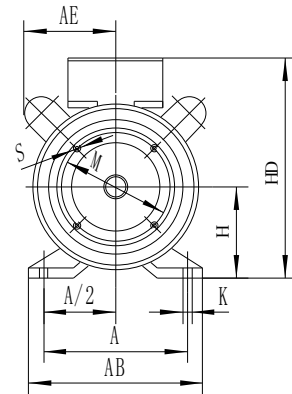
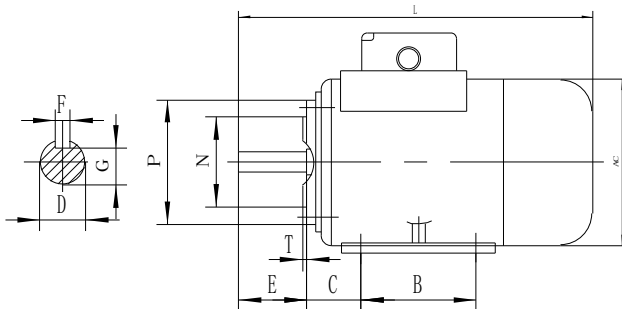

机座号 Frame	IMB3										IMB14					IMB34					IMB5						IMB35						IMB3					
	A	A/2	B	C	D	E	F	G	H	K	M	N	P	R	S	T	M	N	P	R	S	T	M	N	P	R	S	T	AB	AC	AD	AE	HD	L				
YL80	125	62.5	100	50	19	40	6	15.5	80	10	100	80	120	0	M8	3	165	130	200	0	12	3.5	160	165	150	120	200	295										
YL90S	140	70	100	56	24	50	8	20	90	10	115	95	140	0	M8	3	165	130	200	0	12	3.5	180	185	160	130	240	370										
YL90L	140	70	125	56	24	50	8	20	90	10	115	95	140	0	M8	3	165	130	200	0	12	3.5	180	185	160	130	240	400										
YL100L	160	80	140	63	28	60	8	24	100	12							215	180	250	0	15	4	205	220	180	140	260	430										
YL711J	112	56	90	45	16	40	5	13	71	7	85	70	105	0	M6	3.5	130	110	160	0	10	3.5	136	140	110	100	180	265										
YL713J	112	56	90	45	16	40	5	13	71	7	85	70	105	0	M6	3.5	130	110	160	0	10	3.5	136	140	110	100	180	282										

注：IMB14、IMB34、IMB5 的其余尺寸见“IMB3”栏。The other dimensions of IMB14, IMB34 and IMB5 are the same as those of IMB3.