

NS 系列超高效率三相异步电动机

NS Series Stainless Steel Premium- efficiency Washdown Duty Motors

1/4 THRU 30HP

NEMA 56C THRU 286TC

S1

NEMA Premium

TEFC C-FACE WITH BASE



Applications: Food processing, packaging, outdoor and highly corrosive environments.

Features: All external surfaces 300 series stainless steel: motor frame, endplates, conduit box, shaft and base. Four condensate drains in each endplate. Conduit box gasketed. Lip seals. Especially effective in highly corrosive environments where paint or other finishes do not hold up.

Performance Data

TEFC

HP	Full load r/min	Frame	Conn.	Code	Current at 460V			Torque			Efficiency			Power Factor		
					IDLE	Full load (A)	Locked Rotor (A)	Full load (LB-FT)	Locked Rotor %	Break down %	Full load %	3/4 load %	1/2 load %	Full load %	3/4 load %	1/2 load %
1/4	3405	56C	2Y/Y	H	0.22	0.42	10	0.39	230	275	70	71.44	69.63	80	80.36	69.56
1/3	3405	56C	2Y/Y	H	0.32	0.54	10	0.51	230	275	71	73.56	71.40	81	78.15	66.47
1/2	3425	56C	2Y/Y	J	0.41	0.77	10	0.77	230	275	74	77.04	74.90	82	80.11	69.10
3/4	3410	56C	2Y/Y	H	0.59	1.12	12.5	1.16	200	275	75.5	78.11	76.88	83	81.78	71.31
1	3440	56HC	2Y/Y	J	0.63	1.45	15	1.53	185	250	77	81.10	79.73	84	84.96	75.53
1.5	3440	56HC	2Y/Y	H	0.87	1.99	20	2.29	175	250	84	82.91	82.15	84	86.20	77.77
2	3430	56HC	2Y/Y	G	0.91	2.55	25	3.07	170	240	85.5	84.61	83.99	86	89.24	82.72
1/4	1740	56C	2Y/Y	K	0.34	0.46	10	0.76	300	300	74	74.71	72.01	69	64.92	51.73
1/3	1735	56C	2Y/Y	J	0.46	0.58	10	1.00	300	300	76	76.54	72.98	70	65.19	51.84
1/2	1730	56C	2Y/Y	J	0.56	0.82	10	1.52	250	300	77	77.77	75.94	74	69.60	56.48
3/4	1725	56C	2Y/Y	H	0.83	1.22	12.5	2.29	275	300	78	79.36	78.01	74	71.14	58.37
1	1725	56HC	2Y/Y	G	1.06	1.52	15	3.05	250	280	82.5	82.88	81.73	75	71.94	59.16
1.5	1720	56HC	2Y/Y	G	1.34	2.12	20	4.59	250	280	84.0	84.58	83.88	79	75.50	63.49
2	1720	56HC	2Y/Y	G	1.64	2.78	25	6.11	235	270	84.0	85.64	85.00	80	76.83	65.21
1/4	1140	56C	2Y/Y	H	0.52	0.56	10	1.15	175	265	68	69.65	66.05	62	54.66	42.50
1/3	1140	56C	2Y/Y	H	0.61	0.70	10	1.52	175	265	70	72.74	69.69	64	56.17	43.79
1/2	1135	56C	2Y/Y	G	0.80	0.96	10	2.32	175	265	74	75.86	73.48	66	59.02	46.30
3/4	1135	56HC	2Y/Y	G	1.11	1.36	12.5	3.47	175	265	77	79.67	77.59	67	60.05	47.21
1	1135	56HC	2Y/Y	F	1.50	1.72	15	4.63	170	265	80.0	80.69	78.82	68	60.14	47.10
1.5	1130	56HC	2Y/Y	F	2.11	2.58	20	6.98	170	265	80.0	81.88	80.48	68	62.16	48.97
2	1130	56HC	2Y/Y	G	2.88	3.39	25	9.31	170	265	80.0	83.03	81.88	69	64.00	51.30
3/4	3410	143TC	2Y/Y	H	0.59	1.12	12.5	1.16	200	275	75.5	78.11	76.88	83	81.78	71.31



Performance Data

TEFC

HP	Full load r/min	Frame	Conn.	Code	Current at 460V			Torque			Efficiency			Power Factor		
					IDLE	Full load (A)	Locked Rotor (A)	Full load (LB-FT)	Locked Rotor %	Break down %	Full load %	3/4 load %	1/2 load %	Full load %	3/4 load %	1/2 load %
1	3440	143TC	2Y/Y	J	0.63	1.45	15	1.53	185	250	77.0	81.10	79.73	84	84.96	75.53
1.5	3440	143TC	2Y/Y	H	0.87	1.99	20	2.29	175	250	84	85.05	84.71	84	86.20	77.77
2	3430	145TC	2Y/Y	G	0.91	2.55	25	3.07	170	240	85.5	86.15	86.12	86	89.24	82.72
3	3455	145TC	2Y/Y	H	1.31	3.78	32	4.57	160	230	86.5	86.90	85.91	86	89.66	83.30
3/4	1725	143TC	2Y/Y	H	0.83	1.22	12.5	2.29	275	300	78	79.36	71.14	74	78.01	58.37
1	1725	143TC	2Y/Y	G	1.06	1.46	15	3.05	275	300	85.5	84.76	83.20	75	71.94	59.16
1.5	1720	145TC	2Y/Y	G	1.34	2.06	20	4.59	250	280	86.5	86.35	85.13	79	75.50	63.49
2	1720	145TC	2Y/Y	G	1.64	2.71	25	6.11	235	270	86.5	86.82	86.25	80	76.83	65.21
3	1725	145TC	2Y/Y	G	2.57	3.92	32	9.14	215	250	89.5	88.91	88.15	80	77.10	65.61
3/4	1135	143TC	2Y/Y	G	1.11	1.36	12.5	3.47	175	265	77	79.67	77.59	67	60.05	47.21
1	1135	145TC	2Y/Y	F	1.50	1.67	15	4.63	170	265	82.5	82.54	81.31	68	60.14	47.10
3	3510	182TC	2Y/Y	J	1.46	3.73	32	4.49	160	230	86.5	87.25	86.36	87	88.65	81.80
5	3500	184TC	2Y/Y	H	2.26	6.01	46	7.51	150	215	88.5	88.91	88.63	88	89.55	83.35
3	1765	182TC	2Y/Y	J	2.53	3.92	32	8.94	215	250	89.5	89.42	88.18	80	75.25	63.24
5	1760	184TC	2Y/Y	H	3.52	6.54	46	14.94	185	225	89.5	89.32	88.61	80	79.82	69.39
1.5	1175	182TC	2Y/Y	G	1.69	2.29	20	6.71	165	250	87.5	87.32	88.43	70	67.30	54.35
2	1170	184TC	2Y/Y	G	2.09	2.90	25	8.99	160	240	88.5	88.32	86.51	73	69.16	56.42
3	1170	184TC	2Y/Y	F	2.88	4.3	32	13.48	155	230	89.5	89.12	87.61	73	65.35	52.23
7.5	3520	213TC	2Δ/Δ	G	1.72	8.82	63.5	11.20	140	200	89.7	89.82	89.45	89	89.95	84.62
10	3520	215TC	2Δ/Δ	G	1.88	11.53	81	14.94	135	200	90.2	90.76	90.25	90	91.66	87.78
7.5	1760	213TC	2Δ/Δ	G	3.65	9.12	63.5	22.41	175	215	91.7	91.63	91.12	84	81.90	73.06
10	1760	215TC	2Δ/Δ	G	4.10	12.16	81	29.87	165	200	91.7	91.85	91.41	84	83.64	75.83
3	1175	213TC	2Y/Y	G	3.18	4.30	32	13.42	155	230	89.5	89.65	88.42	73.0	68.46	55.95
5	1170	215TC	2Y/Y	F	4.82	6.97	46	22.47	150	215	89.5	90.08	89.46	75.0	71.38	59.35
15	3560	254TC	2Δ/Δ	G	4.35	17.34	116	22.15	180	240	91	91.17	90.0	89	89.0	83.5
20	3560	256TC	2Δ/Δ	G	5.17	22.87	145	29.54	160	220	91	91.25	91.21	90	90.8	87.0
15	1765	254TC	2Δ/Δ	F	7.75	18.31	116	44.68	185	220	92.4	92.42	91.61	83	81.4	71.4
20	1765	256TC	2Δ/Δ	G	9.20	23.97	145	59.58	180	220	93	92.45	92.28	84	85.0	77.6
7.5	1170	254TC	2Δ/Δ	G	5.20	10.29	63.5	33.70	180	220	91	91.17	90.48	75	69.5	57.5
10	1170	256TC	2Δ/Δ	G	6.83	13.54	81	44.94	170	220	91	91.4	90.61	76	70.9	58.7
25	3560	284TSC	2Δ/Δ	F	6.60	28.68	182.5	36.92	170	220	91.7	92.05	91.76	89	89.9	85.1
30	3560	286TSC	2Δ/Δ	E	7.70	34.42	217.5	44.31	170	230	91.7	92.10	92.07	89	90.2	85.7
25	1770	284TC	2Δ/Δ	G	10.50	29.08	182.5	74.26	170	220	93.6	93.42	92.66	86	83.4	74.7
30	1770	286TC	2Δ/Δ	G	12.00	34.90	217.5	89.11	170	220	93.6	93.29	93.12	86	84.5	76.5
15	1175	284TC	2Δ/Δ	G	7.80	19.15	116	67.12	165	220	91.7	91.55	91.15	80	78.7	68.3
20	1175	286TC	2Δ/Δ	F	9.37	25.53	145	89.49	150	210	91.7	91.85	91.18	80	81.9	73.9

* For current at 230V, multiple above values by 2.

Performance Data

TENV

HP	Full load r/min	Frame	Conn.	Code	Current at 460V			Torque			Efficiency			Power Factor		
					IDLE	Full load (A)	Locked Rotor (A)	Full load (LB-FT)	Locked Rotor %	Break down %	Full load %	3/4 load %	1/2 load %	Full load %	3/4 load %	1/2 load %
1/4	3405	56C	2Y/Y	H	0.22	0.42	10	0.39	230	275	70	71.44	69.63	80	80.36	69.56
1/3	3405	56C	2Y/Y	H	0.32	0.54	10	0.51	230	275	71	73.56	71.40	81	78.15	66.47
1/2	3425	56C	2Y/Y	J	0.41	0.77	10	0.77	230	275	74	77.04	74.90	82	80.11	69.10
3/4	3410	56C	2Y/Y	H	0.59	1.12	12.5	1.16	200	275	75.5	78.11	76.88	83	81.78	71.31
1	3440	56HC	2Y/Y	J	0.63	1.45	15	1.53	185	250	77	81.10	79.73	84	84.96	75.53
1/4	1740	56C	2Y/Y	K	0.34	0.46	10	0.76	300	300	74	74.71	72.01	69	64.92	51.73
1/3	1735	56C	2Y/Y	J	0.46	0.58	10	1.00	300	300	76	76.54	72.98	70	65.19	51.84
1/2	1730	56C	2Y/Y	J	0.56	0.82	10	1.52	250	300	77	77.77	75.94	74	69.60	56.48
3/4	1725	56C	2Y/Y	H	0.83	1.22	12.5	2.29	275	300	78	79.36	78.01	74	71.14	58.37
1	1725	56HC	2Y/Y	G	1.06	1.52	15	3.05	250	280	82.5	82.88	81.73	75	71.94	59.16
1.5	1720	56HC	2Y/Y	G	1.34	2.12	20	4.59	250	280	84.0	84.58	83.88	79	75.50	63.49
2	1720	56HC	2Y/Y	G	1.64	2.78	25	6.11	235	270	84.0	85.64	85.00	80	76.83	65.21
1/4	1140	56C	2Y/Y	H	0.52	0.56	10	1.15	175	265	68	69.65	66.05	62	54.66	42.50
1/3	1140	56C	2Y/Y	H	0.61	0.70	10	1.52	175	265	70	72.74	69.69	64	56.17	43.79
1/2	1135	56C	2Y/Y	G	0.80	0.96	10	2.32	175	265	74	75.86	73.48	66	59.02	46.30
3/4	1135	56HC	2Y/Y	G	1.11	1.36	12.5	3.47	175	265	77	79.67	77.59	67	60.05	47.21
1	1135	56HC	2Y/Y	F	1.50	1.72	15	4.63	170	265	80.0	80.69	78.82	68	60.14	47.10
3/4	3410	143TC	2Y/Y	H	0.59	1.12	12.5	1.16	200	275	75.5	78.11	76.88	83	81.78	71.31
1	3440	143TC	2Y/Y	J	0.63	1.45	15	1.53	185	250	77.0	81.10	79.73	84	84.96	75.53
3/4	1725	143TC	2Y/Y	H	0.83	1.22	12.5	2.29	275	300	78	79.36	71.14	74	78.01	58.37
1	1725	143TC	2Y/Y	G	1.06	1.46	15	3.05	275	300	85.5	84.76	83.20	75	71.94	59.16
1.5	1720	145TC	2Y/Y	G	1.34	2.06	20	4.59	250	280	86.5	86.35	85.13	79	75.50	63.49
2	1720	145TC	2Y/Y	G	1.64	2.71	25	6.11	235	270	86.5	86.82	86.25	80	76.83	65.21
3/4	1135	143TC	2Y/Y	G	1.11	1.36	12.5	3.47	175	265	77	79.67	77.59	67	60.05	47.21
1	1135	145TC	2Y/Y	F	1.50	1.67	15	4.63	170	265	82.5	82.54	81.31	68	60.14	47.10

DIMENSION

inch

TEFC

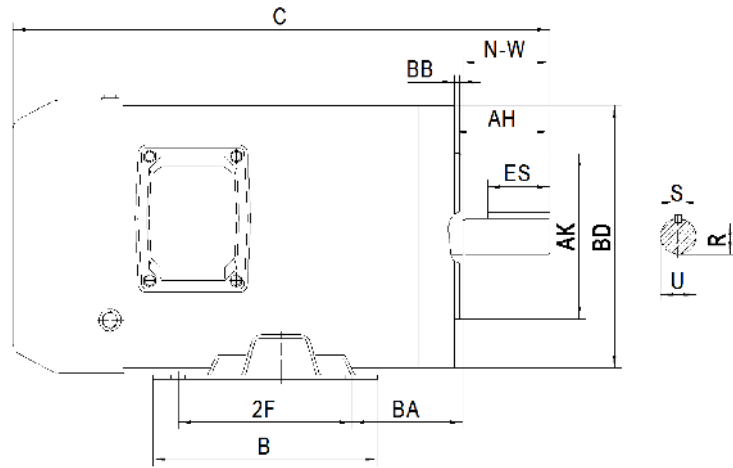
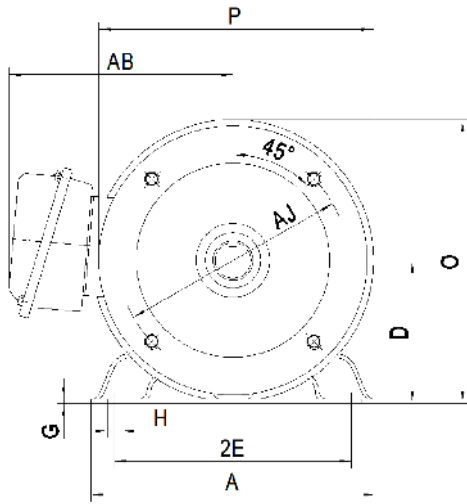

Frame 56-140T

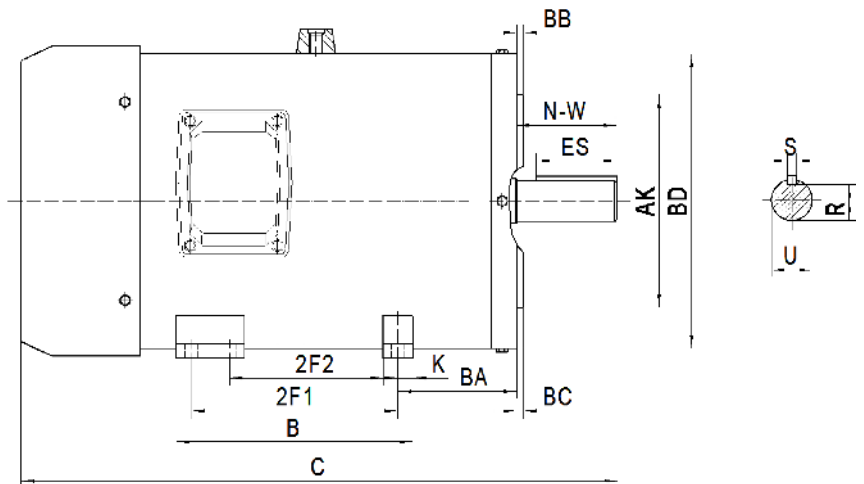
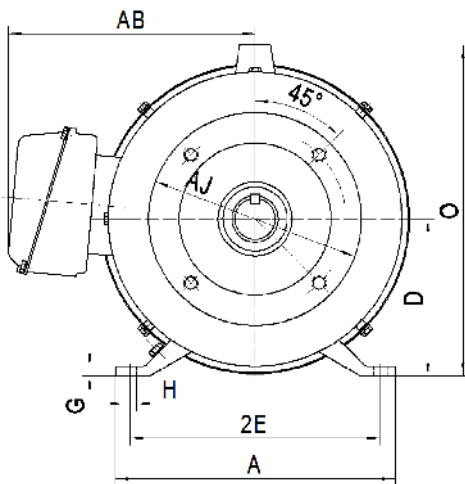

注:2F1 为 184T 和 215T 的 2F 尺寸 ; 2F2 为 182T 和 213T 的 2F 尺寸

Frame 180-210T

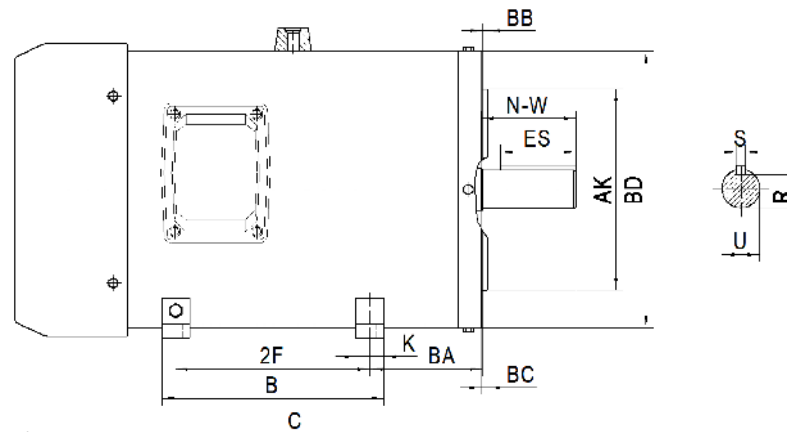
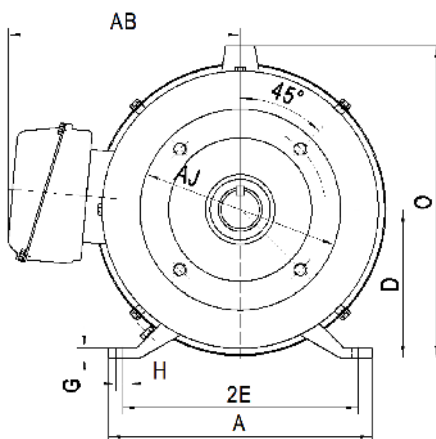

Frame 250T-280T

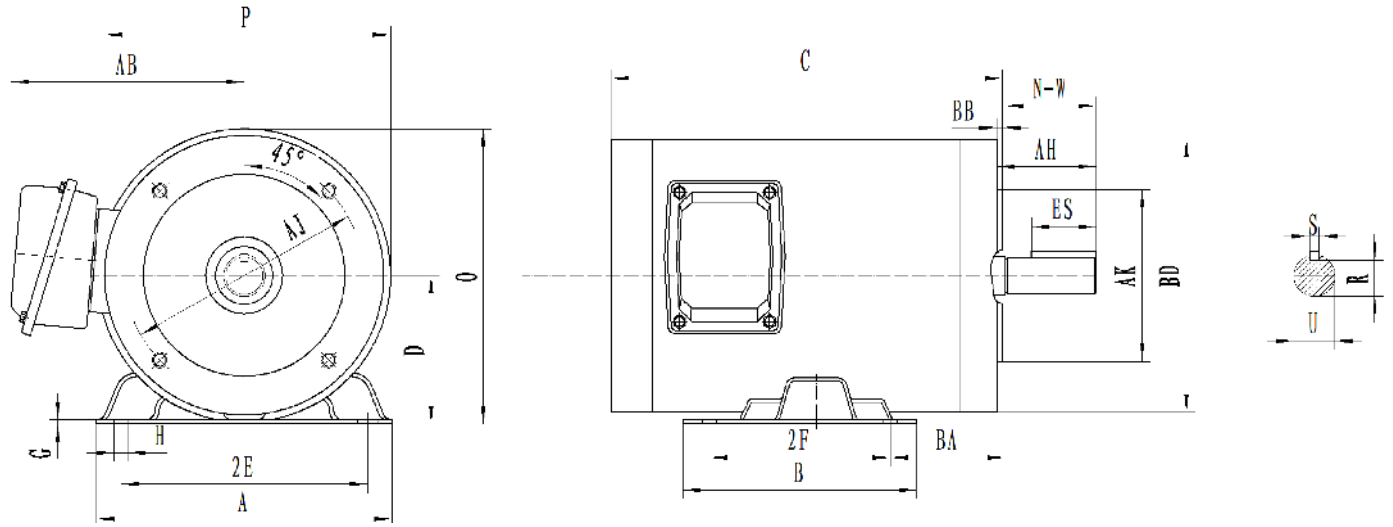
TENV

Frame	MOUNTING			A	B	C		D	G	H	O	P	R	S	AB	SHAFT EXTENSION			BEARINGS	
	2E	2F	BA			TEFC	TENV									N-W	U	V	DRIVE END	OPPOSITE DRIVE END
56C	4.88	3	2.75	6.5	5.0	12.5	10.5	3.5	0.118	0.34	6.8	7.0	0.517	0.188	6.5	1.88	0.625	2	6205	6205
56HC	4.88	5	2.75	6.5	6.5	14.0	12.0	3.5	0.118	0.34	6.8	7.0	0.517	0.188	6.5	1.88	0.625	2	6205	6205
56HC4						16.0	14.0													
143TC	5.5	4	2.75	6.5	5.0	13.4	11.4	3.5	0.118	0.34	6.8	7.0	0.771	0.188	6.5	2.25	0.875	2	6205	6205
145TC	5.5	5	2.75	6.5	6.5	14.2	12.2	3.5	0.118	0.34	6.8	7.0	0.771	0.188	6.5	2.25	0.875	2	6205	6205
145TC2-2						16.2	14.2													
145TC3-4						16.2	14.2													
182TC-2	7.5	4.5	3.5	8.6	6.7	17.3	-	4.5	0.394	0.41	9.2	8.9	0.986	0.25	7.1	2.75	1.125	2.5	6306	6306
184TC-2	7.5	5.5	3.5	8.6	6.7	17.9	-	4.5	0.394	0.41	9.2	8.9	0.986	0.25	7.1	2.75	1.125	2.5	6306	6306
184TC2-6						17.9	-													
182TC-4/6	7.5	4.5	3.5	8.6	6.7	16.5	-	4.5	0.394	0.41	9.3	8.9	0.986	0.25	7.1	2.75	1.125	2.5	6306	6306
184TC-4/6	7.5	5.5	3.5	8.6	6.7	17.1	-	4.5	0.394	0.41	9.3	8.9	0.986	0.25	7.1	2.75	1.125	2.5	6306	6306
213TC	8.5	5.5	4.25	9.6	8.2	20.5	-	5.25	0.394	0.41	11.0	10.2	1.201	0.312	8.27	3.38	1.375	3.12	6208	6208
215TC	8.5	7	4.25	9.6	8.2	22	-	5.25	0.394	0.41	11.0	10.2	1.201	0.312	8.27	3.38	1.375	3.12	6208	6208
254TC	10	8.25	4.75	11.2	9.45	23.8	-	6.25	0.394	0.53	13.2	12.3	1.416	0.375	9.85	4	1.625	3.75	6309	6309
256TC	10	10	4.75	11.2	12.2	25.4	-	6.25	0.394	0.53	13.2	12.3	1.416	0.375	9.85	4	1.625	3.75	6309	6309
284TSC	11	9.5	4.75	12.2	11.00	25.4	-	7	0.472	0.53	14.7	13.8	1.416	0.375	9.85	3.25	1.625	3	6310	6310
284TC	11	9.5	4.75	12.2	11.00	26.8	-	7	0.472	0.53	14.7	13.8	1.591	0.5	9.85	4.62	1.875	4.38	6310	6310
286TSC	11	11	4.75	12.2	12.50	26.4	-	7	0.472	0.53	14.7	13.8	1.416	0.375	9.85	3.25	1.625	3	6310	6310
286TC	11	11	4.75	12.2	12.50	27.8	-	7	0.472	0.53	14.7	13.8	1.591	0.5	9.85	4.62	1.875	4.38	6310	6310



FRAME	AJ	AK	BA	MIN BB	BC	MAX BD	NUMBER OF HOLE	SCREW	DEPTH OF HOLE	U	AH	Key seal		
												R	ES	S
56C. 56HC	5.875	4.5	2.75	0.16	-0.19	6.5	4	3/8-16	-	0.625	2.06	0.517	1.41	0.188
143TC. 145TC	5.875	4.5	2.75	0.16	+0.12	6.5	4	3/8-16	0.56	0.875	2.12	0.771	1.41	0.188
182TC.184TC	7.25	8.5	3.5	0.25	+0.12	9.0	4	1/2-13	0.75	1.125	2.62	0.986	1.78	0.250
213TC.215TC	7.25	8.5	4.25	0.25	+0.25	9.0	4	1/2-13	0.75	1.375	3.12	1.201	2.41	0.312
254TC.256TC	7.25	8.5	4.75	0.25	+0.25	10.0	4	1/2-13	0.75	1.625	3.75	1.416	2.91	0.375
284TSC.286TSC	9	10.5	4.75	0.25	+0.25	11.25	4	1/2-13	0.75	1.625	3.0	1.416	1.91	0.375
284TC.286TC	9	10.5	4.75	0.25	+0.25	11.25	4	1/2-13	0.75	1.875	4.38	1.591	3.28	0.5