

NEP 系列高效率三相异步电动机

NEP Series Premium- Efficiency Three-phase Induction Motors

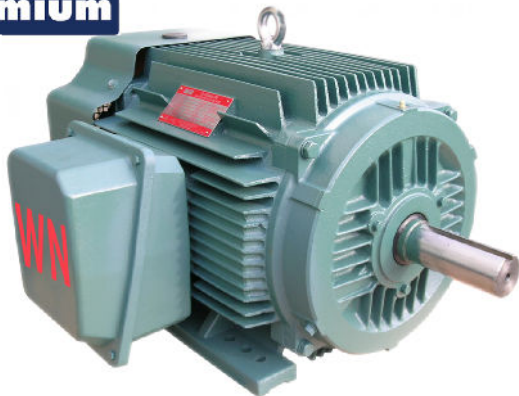

NEMA 140T THRU 449T 1 THRU 250HP

TEFC

NEMA PREMIUM EFFICIENCY

Applications: Typical applications include operations where continuous or frequent duty is required. Constant torque operation is 10:1, Variable torque operation is from zero to base speed. Premium-efficiency motors are designed to conserve energy over extended time period. Class F insulated, 1.15 service factor.

Features: Low-loss electrical grade lamination steel. Cast iron frames, IP55 protection, double lip seal keeps moisture and contamination. Over size bearing, spike resistant magnet wire, conduit box fully gasket and ground lug in conduit box. Stainless steel nameplate. C&D face kits available.

Performance Data

HP	Full Load r/min	Frame	Conn.	Code	Current at 460V			Torque			Efficiency			Power Factor		
					Idle	Full load (A)	Locked rotor (A)	Full load (LB-FT)	Locked rotor %	Break down %	Full load %	3/4 load %	1/2 load %	Full load %	3/4 load %	1/2 load %
1	1150	145T	2Y/Y	H	1.00	1.7	8	4.60	230	275	82.5	82.12	81.04	68	67.49	54.41
1	1750	143T2	2Y/Y	K	1.04	1.5	11	3.02	250	300	85.5	84.98	83.55	78	70.61	58.10
1	3495	143T1	2Y/Y	K	0.94	1.5	11	1.51	250	300	77.0	76.34	75.03	82	76.83	64.75
1.5	1180	182T	2Y/Y	H	1.79	2.2	14	6.69	200	285	87.5	87.15	85.51	75	68.11	54.30
1.5	1745	145T1	2Y/Y	J	1.46	2.1	15	4.52	265	280	86.5	86.28	85.35	78	72.75	60.94
1.5	3495	143T3	2Y/Y	K	0.96	2.0	16	2.26	250	300	84.0	85.16	84.86	84	84.65	75.38
2	1180	184T	2Y/Y	J	1.70	2.9	18	8.90	200	280	88.5	88.13	86.56	75	68.82	54.73
2	1740	145T2	2Y/Y	J	1.50	2.8	19	6.04	260	280	86.5	86.77	86.20	78	75.35	64.16
2	3485	145T	2Y/Y	J	0.90	2.6	19	3.01	220	265	85.5	86.05	86.26	85	88.27	81.66
3	1180	213T	2Y/Y	J	2.40	4.2	29	13.38	200	250	89.6	89.59	88.50	75	73.06	61.11
3	1765	182T	2Y/Y	J	1.83	3.7	29	8.94	210	300	89.5	89.23	88.35	86	81.22	71.15
3	3540	182T	2Y/Y	J	1.70	3.8	30	4.46	200	280	87.1	87.30	86.53	87	85.07	76.32
5	1180	215T	2Y/Y	J	3.50	6.9	46	22.28	200	250	89.5	90.03	89.51	76	77.05	66.40
5	1755	184T	2Y/Y	H	3.30	6.1	42	14.98	220	270	89.5	89.22	88.69	86	82.18	72.80
5	3530	184T	2Y/Y	H	2.35	6.1	44	7.45	200	280	88.5	89.01	88.70	88	87.89	81.03
7.5	1185	254T	2Δ/Δ	G	4.60	10.3	59	33.07	220	250	91.0	91.11	90.35	75	74.00	63.20
7.5	1770	213T	2Δ/Δ	G	3.70	9.1	56	22.30	210	260	91.7	91.52	91.06	85	82.64	73.65
7.5	3535	213T	2Δ/Δ	H	2.70	9.0	59	11.16	210	280	89.7	89.95	89.49	88	89.30	83.60
10	1185	256T	2Δ/Δ	G	5.70	13.8	79	44.37	220	250	91.2	91.47	90.85	75	74.80	64.30
10	1765	215T	2Δ/Δ	F	4.45	12.1	69	29.79	200	250	91.7	91.76	91.58	85	84.48	76.84
10	3530	215T	2Δ/Δ	G	3.10	11.8	78	14.89	220	270	90.4	90.81	90.51	88	90.70	86.00
15	1185	284T	2Δ/Δ	G	7.42	19.0	108	66.55	210	250	91.7	91.63	91.07	81	79.62	69.97

HP	Full Load r/min	Frame	Conn.	Code	Current at 460V			Torque			Efficiency			Power Factor		
					Idle	Full load (A)	Locked rotor (A)	Full load (LBFT)	Locked rotor %	Break down %	Full load %	3/4 load %	1/2 load %	Full load %	3/4 load %	1/2 load %
15	1775	254T	2Δ/Δ	G	5.20	17.9	111	44.43	210	260	92.4	92.25	91.79	85	87.11	80.54
15	3560	254T	2Δ/Δ	G	4.56	17.4	113	22.15	210	260	91.2	91.19	90.85	89	91.87	88.10
20	1185	286T	2Δ/Δ	G	9.10	25.3	143	88.74	200	230	91.7	91.74	91.37	81	80.69	71.97
20	1775	256T	2Δ/Δ	G	6.95	23.7	144	59.24	200	250	93.0	92.59	92.23	85	87.79	81.76
20	3555	256T	2Δ/Δ	F	5.20	23.2	140	29.58	200	250	91.2	91.31	91.16	89	92.48	89.54
25	1185	324T	2Δ/Δ	F	11.4	30.7	169	110.92	200	230	93.0	92.97	92.45	82	80.62	71.93
25	1775	284T	2Δ/Δ	F	7.50	28.8	167	74.05	200	245	93.6	93.16	92.77	87	88.30	82.90
25	3565	284TS	2Δ/Δ	F	4.80	28.4	168	36.87	200	250	91.7	92.00	91.84	90	93.20	91.30
30	1185	326T	2Δ/Δ	E	12.3	36.9	188	133.11	210	230	93.0	93.10	92.76	82	81.37	73.53
30	1775	286T	2Δ/Δ	F	8.80	34.5	194	88.86	210	250	93.6	93.38	93.06	87	89.00	84.30
30	3560	286TS	2Δ/Δ	F	5.65	34.1	201	44.31	200	240	91.9	92.27	92.17	90	93.10	91.30
40	1190	364T	2Δ/Δ	G	15.1	46.3	285	176.73	220	240	94.1	94.07	93.57	86	83.51	76.37
40	1780	324T	2Δ/Δ	F	13.7	45.3	271	118.15	190	250	94.1	93.66	93.30	88	85.96	79.26
40	3570	324TS	2Δ/Δ	E	10.8	45.1	244	58.91	190	250	92.4	92.06	91.63	90	90.89	86.93
50	1190	365T	2Δ/Δ	F	18.2	57.9	341	220.91	200	230	94.1	94.24	93.83	86	84.26	77.84
50	1780	326T	2Δ/Δ	F	16.4	56.3	340	147.69	200	250	94.5	94.04	93.68	88	87.17	81.09
50	3570	326TS	2Δ/Δ	E	11.3	56.0	299	73.64	185	250	93.0	92.75	92.36	90	91.40	87.92
60	1190	404T	2Δ/Δ	F	21.6	69.2	406	265.10	190	240	94.5	94.43	94.09	86	84.95	78.00
60	1785	364T	2Δ/Δ	F	19.3	68	412	176.73	190	250	95.0	94.14	93.77	87	87.17	81.18
60	3575	364TS	2Δ/Δ	F	12.5	66.7	403	88.24	190	250	93.6	93.36	93.02	90	93.36	91.09
75	1190	405T	2Δ/Δ	G	25.8	86.5	531	331.43	190	230	94.5	94.69	94.32	86	85.15	78.46
75	1785	365T	2Δ/Δ	F	24.3	84.7	521	220.95	200	250	95.4	94.47	94.10	87	87.67	81.88
75	3575	365TS	2Δ/Δ	F	14.6	83.4	479	110.32	180	230	93.6	93.83	93.59	90	93.22	91.10
100	1190	444T	2-Δ	F	36.5	115	691	441.83	180	230	95.0	94.77	94.28	86	83.25	75.54
100	1785	405T	2Δ/Δ	F	33.0	113	674	294.55	180	250	95.4	94.81	94.39	87	86.20	79.69
100	3575	405TS	2Δ/Δ	F	22.4	110	667	147.07	180	250	94.1	94.17	94.01	91	92.74	90.20
125	1190	445T	2-Δ	F	40.4	144	852	552.28	180	230	95.0	95.02	94.57	86	84.28	77.29
125	1790	444T	2-Δ	F	32.9	140	828	367.16	180	240	95.4	95.03	94.67	88	89.50	85.07
125	3580	444TS	Δ	F	24.1	136	810	183.58	165	230	95.0	95.01	94.00	91	92.01	89.01
150	1190	447T	2-Δ	F	42.5	171	1041	662.74	170	230	95.8	95.28	94.78	86	85.25	78.75
150	1790	445T	2-Δ	F	36.4	167	982	440.59	170	240	95.8	95.28	94.94	88	90.34	86.60
150	3580	445TS	Δ	F	35.8	163	980	220.30	160	230	95.0	95.05	93.80	91	92.08	89.38
200	1190	449T	2-Δ	F	50.8	228	1376	883.65	170	220	95.8	95.49	95.06	86	86.06	80.34
200	1790	447T	2-Δ	F	42.1	222	1325	587.46	185	240	96.2	95.59	95.23	88	90.47	86.70
200	3580	447TS	Δ	F	36.0	214	1284	293.73	170	220	95.4	95.12	93.81	92	92.34	90.54
250	1790	449T	2-Δ	F	46.6	277	1667	734.32	185	230	96.2	95.82	95.49	88	91.13	88.01
250	3580	449TS	Δ	F	33.5	266	1550	367.16	185	220	95.8	95.41	94.30	92	92.41	91.03

NOTE: For current at 230V, multiple above values by 2.

外形及安装尺寸 Dimensions

inch

FOOT MOUNTING DIMENSION

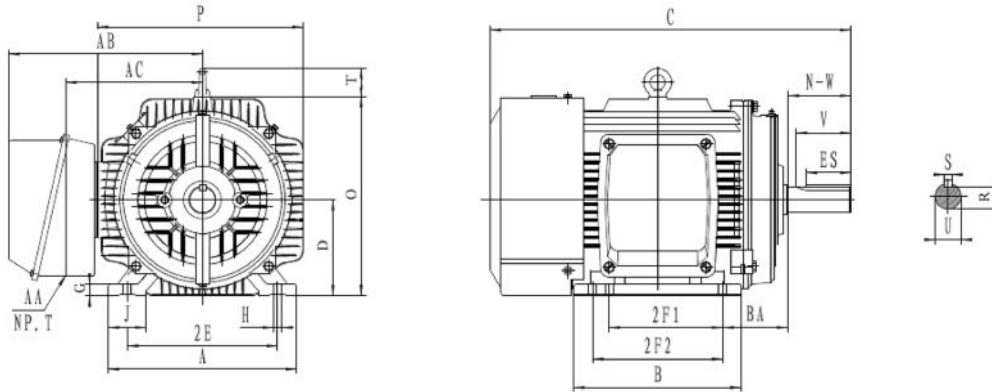

Frame	MOUNTING					A	B	C	D	G	J	O	P	R	S	T	AB	AC	AA	SHAFT EXTENSION			BEARINGS	
	2E	2F1	2F2	H	BA															NW	U	V	DRIVE END	OPPOSITE DRIVE END
143T	5.5	4.0	—	0.3	2.2	7.0	5.8	13.2	3.5	0.46	1.26	7.3	7.1	0.77	0.18	0	6.7	5	3/4	2.25	0.875	2.0	6205-2	6205-2RS
145T	5.5	4.0	5.0	0.3	2.2	7.0	6.8	14.5	3.5	0.46	1.26	7.3	7.1	0.77	0.18	0	6.7	5	3/4	2.25	0.875	2.0	6205-2	6205-2RS
182T	7.5	4.5	—	0.4	2.7	9	7.7	16.7	4.5	0.51	1.77	9.1	9.37	0.98	0.25	1.58	7.8	6.1	3/4	2.75	1.125	2.5	6206-2	6206-2RS
184T	7.5	4.5	5.5	0.4	2.7	9	8.7	17.7	4.5	0.51	1.77	9.1	9.37	0.98	0.25	1.58	7.8	6.1	3/4	2.75	1.125	2.5	6206-2	6206-2RS
213T	8.5	5.5	—	0.4	3.5	10	7.2	18.9	5.25	0.71	2.17	10.9	10.9	1.20	0.31	1.97	10	7.7	1	3.38	1.375	3.1	6208-2	6208-2RS
215T	8.5	5.5	7.0	0.4	3.5	10	8.6	20.5	5.25	0.71	2.17	10.9	10.9	1.20	0.31	1.97	10	7.7	1	3.38	1.375	3.1	6208-2	6208-2RS
254T	10	8.2	—	0.5	4.2	12	10.1	23.5	6.25	0.83	2.56	13	13.2	1.41	0.37	2.35	11	8.6	1-1/4	4.0	1.625	3.7	6309	6309
256T	10	8.2	10	0.5	4.2	12	12.3	25.2	6.25	0.83	2.56	13	13.2	1.41	0.37	2.35	11	8.6	1-1/4	4.0	1.625	3.7	6309	6309
284T	11	9.5	—	0.5	4.7	14	12.5	26.6	7	0.94	2.76	14.6	14.8	1.59	0.5	2.35	14.2	10	1-1/4	4.62	1.875	4.3	6311	6311
284TS	11	9.5	—	0.5	4.7	14	12.5	25.2	7	0.94	2.76	14.6	14.8	1.41	0.37	2.35	14.2	10	1-1/4	3.25	1.625	3	6311	6311
286T	11	9.5	11	0.5	4.7	14	13.8	28.1	7	0.94	2.76	14.6	14.8	1.59	0.5	2.35	14.2	10	1-1/4	4.62	1.875	4.3	6311	6311
286TS	11	9.5	11	0.5	4.7	14	13.8	26.7	7	0.94	2.76	14.6	14.8	1.41	0.37	2.35	14.2	10	1-1/4	3.25	1.625	3	6311	6311
324T	12	10	—	0.6	5.2	16	14.8	31.7	8	0.98	2.76	16.4	16.7	1.84	0.5	2.5	15	10.9	2	5.25	2.125	5	6312	6312
324TS	12	10	—	0.6	5.2	16	14.8	30.2	8	0.98	2.76	16.4	16.7	1.59	0.5	2.5	15	10.9	2	3.75	1.875	3.5	6312	6312
326T	12	10	12	0.6	5.2	16	16.3	33.3	8	0.98	2.76	16.4	16.7	1.84	0.5	2.5	15	10.9	2	5.25	2.125	5	6312	6312
326TS	12	10	12	0.6	5.2	16	16.3	31.7	8	0.98	2.76	16.4	16.7	1.59	0.5	2.5	15	10.9	2	3.75	1.875	3.5	6312	6312
364T	14	11	—	0.6	5.8	18	14	33.7	9	0.98	3.11	18.3	18.1	2.02	0.62	2.5	17.5	12.8	3	5.88	2.375	5.6	6314	6314
364TS	14	11	—	0.6	5.8	18	14	31.5	9	0.98	3.11	18.3	18.1	1.59	0.5	2.5	17.5	12.8	3	3.75	1.875	3.5	6314	6314
365T	14	11	12	0.6	5.8	18	17.3	37.1	9	0.98	3.11	18.3	18.1	2.02	0.62	2.5	17.5	12.8	3	5.88	2.375	5.6	6314	6314
365TS	14	11	12	0.6	5.8	18	17.3	34.6	9	0.98	3.11	18.3	18.1	1.59	0.5	2.5	17.5	12.8	3	3.75	1.875	3.5	6314	6314
404T	16	12	—	0.8	6.6	20	19	40	10	1.18	3.15	20.1	20.3	2.45	0.75	2.5	18.8	14	3	7.25	2.875	7	6316	6316
404TS	16	12	—	0.8	6.6	20	19	37	10	1.18	3.15	20.1	20.3	1.84	0.5	2.5	18.8	14	3	4.25	2.125	4	6316	6316
405T	16	12	13	0.8	6.6	20	19	40	10	1.18	3.15	20.1	20.3	2.45	0.75	2.5	18.8	14	3	7.25	2.875	7	6316	6316
405TS	16	12	13	0.8	6.6	20	19	37	10	1.18	3.15	20.1	20.3	1.84	0.5	2.5	18.8	14	3	4.25	2.125	4	6316	6316
444T	18	14	—	0.8	7.5	22	20	45.1	11	1.38	3.46	22.8	23.1	2.88	0.87	3.7	19.7	14.7	3	8.5	3.375	8.2	NU318	6318
444TS	18	14	—	0.8	7.5	22	20	41.4	11	1.38	3.46	22.8	23.1	2.02	0.62	3.7	19.7	14.7	3	4.75	2.375	4.5	6316	6316
445T	18	14	16	0.8	7.5	22	20	45.1	11	1.38	3.46	22.8	23.1	2.88	0.87	3.7	19.7	14.7	3	8.5	3.375	8.2	NU318	6318
445TS	18	14	16	0.8	7.5	22	20	41.4	11	1.38	3.46	22.8	23.1	2.02	0.62	3.7	19.7	14.7	3	4.75	2.375	4.5	6316	6316
447T	18	20	—	0.8	7.5	22	28	53.6	11	1.38	3.46	22.8	23.1	2.88	0.87	3.7	19.7	14.7	3	8.5	3.375	8.2	NU320	6320
447TS	18	20	—	0.8	7.5	22	28	50	11	1.38	3.46	22.8	23.1	2.02	0.62	3.7	19.7	14.7	3	4.75	2.375	4.5	6316	6316
449T	18	20	25	0.8	7.5	22	28	53.6	11	1.38	3.46	22.8	23.1	2.88	0.87	3.7	19.7	14.7	3	8.5	3.375	8.2	NU320	6320
449TS	18	20	25	0.8	7.5	22	28	50	11	1.38	3.46	22.8	23.1	2.02	0.62	3.7	19.7	14.7	3	4.75	2.375	4.5	6316	6316

TEFC C-FACE MOUNTING DIMENSIONS

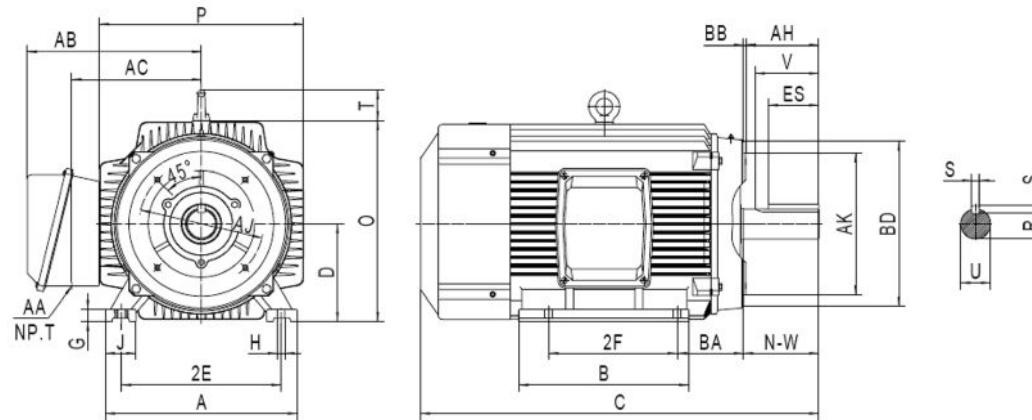

FRAME	AJ	AK	BA	MIN BB	BC	MAX BD	NUMBER OF HOLE	SCREW	DEPTH OF HOLE	U	AH	R	ES	S
143TC.145TC	5.875	4.500	2.70	0.16	0.12	6.50	4	3/8-16	0.56	0.875	2.12	0.771	1.41	0.188
182TC.184TC	7.25	8.500	3.50	0.25	0.12	9	4	1/2-13	0.75	1.125	2.62	0.986	1.78	0.250
213TC.215TC	7.25	8.500	3.50	0.25	0.25	9	4	1/2-13	0.75	1.375	3.12	1.201	2.41	0.312
254TC.256TC	7.25	8.500	4.75	0.25	0.25	10	4	1/2-13	0.75	1.625	3.75	1.416	2.91	0.375
284TC.286TC	9.000	10.500	4.75	0.25	0.25	11.25	4	1/2-13	0.75	1.875	4.38	1.591	3.28	0.500
284TSC.286TSC	9.000	10.500	4.75	0.25	0.25	11.25	4	1/2-13	0.75	1.625	3.00	1.416	1.91	0.375
324TC.326TC	11.000	12.500	5.25	0.25	0.25	14.00	4	5/8-11	0.94	2.125	5.00	1.845	3.91	0.500
324TSC.326TSC	11.000	12.500	5.25	0.25	0.25	14.00	4	5/8-11	0.94	1.875	3.50	1.591	2.03	0.500
364TC.365TC	11.000	12.500	5.88	0.25	0.25	14.00	8	5/8-11	0.94	2.375	5.62	2.021	4.28	0.625
364TSC.365TSC	11.000	12.500	5.88	0.25	0.25	14.00	8	5/8-11	0.94	1.875	3.50	1.591	2.03	0.500
404TC.405TC	11.000	12.500	6.62	0.25	0.25	15.50	8	5/8-11	0.94	2.875	7.00	2.45	5.65	0.750
404TSC.405TSC	11.000	12.500	6.62	0.25	0.25	15.50	8	5/8-11	0.94	2.125	4.00	1.845	2.78	0.500
444TC.445TC	14.000	16.000	7.5	0.25	0.25	18.00	8	5/8-11	0.94	3.375	8.25	2.88	6.91	0.875
444TSC.445TSC	14.000	16.000	7.5	0.25	0.25	18.00	8	5/8-11	0.94	2.375	4.50	2.021	3.03	0.625
447TC.449TC	14.000	16.000	7.5	0.25	0.25	18.00	8	5/8-11	0.94	3.375	8.25	2.88	6.91	0.875
447TSC.449TSC	14.000	16.000	7.5	0.25	0.25	18.00	8	5/8-11	0.94	2.375	4.50	2.021	3.03	0.625

TEFC D-FACE MOUNTING DIMENSIONS

inch

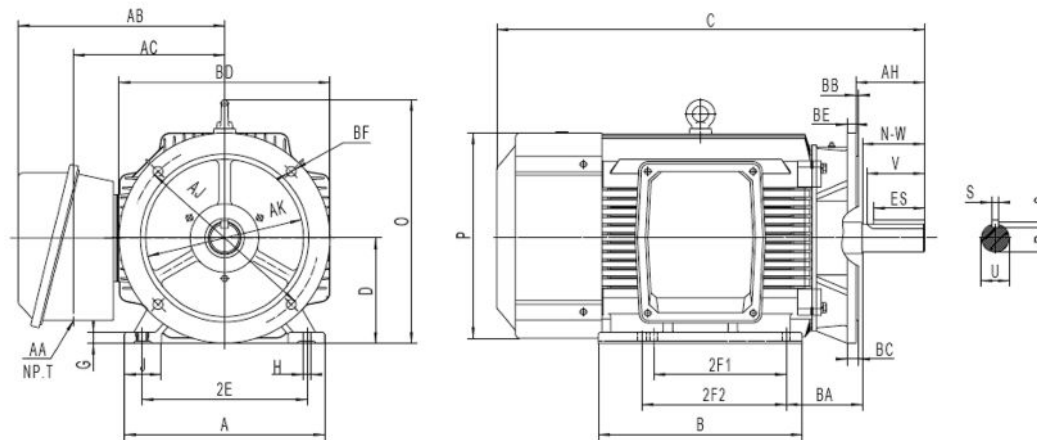

FRAME	AJ	AK	BA	MIN BB	BC	MAX BD	BE	NUMBER OF HOLE	SCREW	DEPTH OF HOLE	U	AH	R	ES	S
143TD.145TD	10.00	9.000	2.75	0.25	0.00	11.00	0.5	4	0.53	1.25	0.875	2.25	0.771	1.41	0.188
182TD.184TD	10.00	9.000	3.5	0.25	0.00	11.00	0.5	4	0.53	1.25	1.125	2.75	0.986	1.78	0.250
213TD.215TD	10.00	9.000	3.5	0.25	0.00	11.00	0.5	4	0.53	1.25	1.375	3.38	1.201	2.41	0.312
254TD.256TD	12.50	11.000	4.75	0.25	0.00	14.00	0.75	4	0.81	2.00	1.625	4.00	1.416	2.91	0.375
284TD.286TD	12.50	11.000	4.75	0.25	0.00	14.00	0.75	4	0.81	2.00	1.875	4.62	1.591	3.28	0.500
284TSD.286TSD	12.50	11.000	4.75	0.25	0.00	14.00	0.75	4	0.81	2.00	1.625	3.25	1.416	1.91	0.375
324TD.326TD	16.00	14.000	5.25	0.25	0.00	18.00	0.75	4	0.81	2.00	2.125	5.25	1.845	3.91	0.500
324TSD.326TSD	16.00	14.000	5.25	0.25	0.00	18.00	0.75	4	0.81	2.00	1.875	3.75	1.591	2.03	0.500
364TD.365TD	16.00	14.000	5.88	0.25	0.00	18.00	0.75	4	0.81	2.00	2.375	5.88	2.021	4.28	0.625
364TSD.365TSD	16.00	14.000	5.88	0.25	0.00	18.00	0.75	4	0.81	2.00	1.875	3.75	1.591	2.03	0.500
404TD.405TD	20.00	18.000	6.62	0.25	0.00	22.00	1.00	8	0.81	2.25	2.875	7.25	2.45	5.65	0.750
404TSD.405TSD	20.00	18.000	6.62	0.25	0.00	22.00	1.00	8	0.81	2.25	2.125	4.25	1.845	2.78	0.500
444TD.445TD	20.00	18.000	7.5	0.25	0.00	22.00	1.00	8	0.81	2.25	3.375	8.50	2.88	6.91	0.875
444TSD.445TSD	20.00	18.000	7.5	0.25	0.00	22.00	1.00	8	0.81	2.25	2.375	4.75	2.021	3.03	0.625
447TD.449TD	20.00	18.000	7.5	0.25	0.00	22.00	1.00	8	0.81	2.25	3.375	8.50	2.88	6.91	0.875
447TSD.449TSD	20.00	18.000	7.5	0.25	0.00	22.00	1.00	8	0.81	2.25	2.375	4.75	2.021	3.03	0.625

NOTE:

1. Tolerance on dimension D: +0.00inch, -1/32 inch for frame 143~326; +0.00 inch -1/16 inch for frames 364~449.
 2. Tolerance on shaft diameter U: +0.0000 inch, -0.0005 inch for frames 143~215; +0.000 inch, 0.001 inch for frame 254~449.
 3. Tolerance on dimension R: +0.000 inch, -0.015 inch.
 4. Dimension V is length of straight part shaft.
 5. The conduit box can be rotated 90° increments so that conduit can be received from any direction. Conduit box can be located on either side of the motor.
 6. The last letter "Z" designated suitability for belt drive application.
- ALL DATA SUBJECT TO CHANGE WITHOUT NOTICE. USE ONLY CERTIFIED DATA FOR CONSTRUCTION PURCHASES.