

YCT 系列电磁调速电动机

YCT Series Electromagnetic Speed Adjustable Motors



机座号 112~355
调速范围 1: 10

功率 0.55KW~90KW
防护等级 IP21

适用于: 恒转矩无级调速的场合, 特别适用于风机、水泵等递减转矩负载。

Applications: fans, pumps and such instruments with decreasing load

特点: 恒转矩无级调速、结构简单、操作维修方便、运行可靠。
Features: Stepless adjustable speed with constant torque. Ease to operation.

使用条件: 海拔不超过 1000m; 环境空气温度随季节而变化, 但最高不超过 40°C。少尘、无铁磁性物质尘埃、无腐蚀金属破坏绝缘和爆炸性的气体。

性能数据 Performance Data

380V 50Hz

型号 Type	标称功率 Nominal Output kW	额定转矩 Rated Torque N.m	额定调速范围 Speed Range r/min	型号 Type	标称功率 Nominal Output kW	额定转矩 Rated Torque N.m	额定调速范围 Speed Range r/min
YCT112-4A	0.55	3.6	1230~125	YCT225-4B	15	94	1250~125
YCT112-4B	0.75	4.9	1230~125	YCT250-4A	18.5	110	1320~132
YCT132-4A	1.1	7.1	1230~125	YCT250-4B	22	137	1320~132
YCT132-4B	1.5	9.7	1230~125	YCT280-4A	30	189	1320~132
YCT160-4A	2.2	14.1	1250~125	YCT315-4A	37	232	1320~132
YCT160-4B	3	19.2	1250~125	YCT315-4B	45	282	1320~132
YCT180-4A	4	25.2	1250~125	YCT355-4A	55	344	1340~440
YCT200-4A	5.5	36.1	1250~125	YCT355-4B	75	469	1340~440
YCT200-4B	7.5	47.7	1250~125	YCT355-4C	90	564	1340~600
YCT225-4A	11	69	1250~125				

注: 1. 标称功率为拖动电机的额定功率。The nominal output is the rated output of the driving motor.

调速电动机的输出功率 the output of the regulating shaft is:

$$P_2 = \frac{T_2 \times n_2}{9.55} \times 0.001$$

P_2 — 输出功率, kW

T_2 — 输出转矩, N·m

n_2 — 输出转速, r/min

2. 表中数据允许变动, 恕不另行通知。

All data subject to change without notice. Use only certified data for purchases.

CTK 型 (JD1 型) 电磁调速电动机控制器

Model CTK (JD1) eddy-current coupling drive controllers

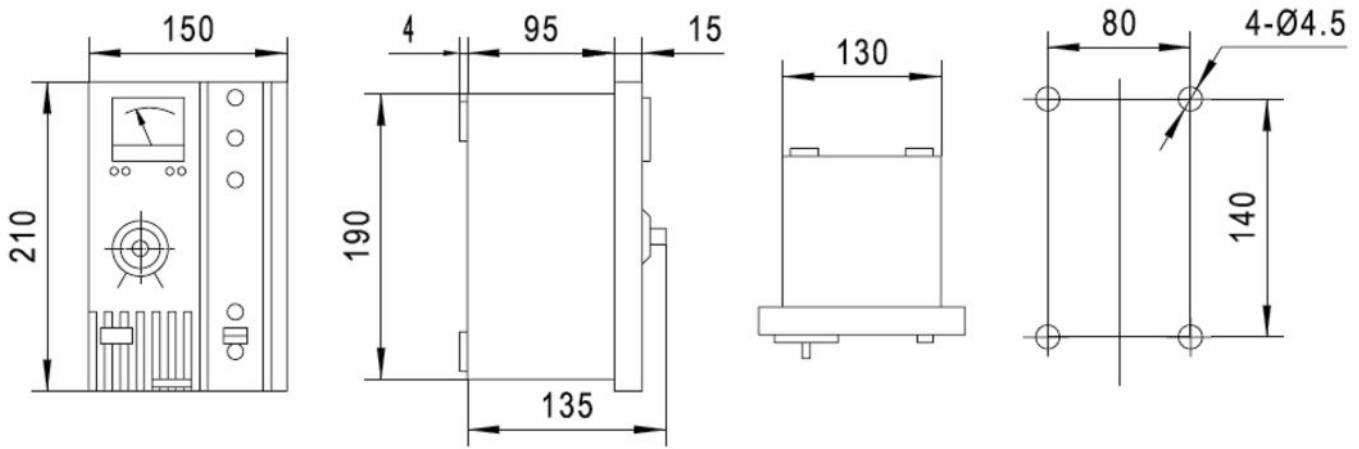

技术参数 Technical Data

380V 50Hz

型 号 Type		CTK-A30 (JD1A-40)	CTK-A90 (JD1A-90)	CTK-B30 (JD1B-40)	CTK-B90 (JD1B-90)
电 源 Input Power	电压 V	220 ± 10%			
	频率 Hz	50 ± 2%			
额定直流输出 DC Rated Output	电压 V	≥ 80			
	电流 A	4	6.3	4	6.3
可控电机功率 kW Power range of controlled motor		0.55~30	37~90	0.55~30	37~90
转速变化率 % Speed variation ratio		2.5		1.0	
稳速精度 % Accuracy of speed stability		≤ 1			
端子标志 Terminal Mark		输入 input 1 相线 phase terminal 2 零线 zero line	输出 output 3 + 4 -	测速发电机 tachogenerator 5 6 7	

控制器输出电流允许短时过载 20%，时间不超过 10min。

The output current of the controller can be withstanding 20% overload within 10min.

外形及安装尺寸 Dimensions

mm

YCT

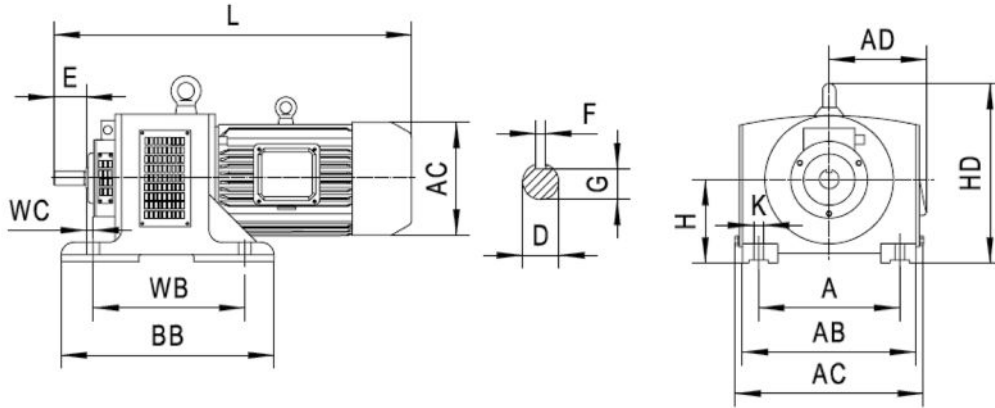

型号 Type	安装尺寸 Mounting Dimensions									外形尺寸 Overall Dimensions				
	A	WB	WC	E	H	D	F	G	K	AB	AC	AD	HD	L
YCT112-4A	190	210	40	40	112	19	6	15.5	12	240	260	150	280	520
YCT112-4B	190	210	40	40	112	19	6	15.5	12	240	260	150	280	520
YCT132-4A	216	241	40	50	132	24	8	20	12	285	310	165	330	570
YCT132-4B	216	241	40	50	132	24	8	20	12	285	310	165	330	585
YCT160-4A	254	267	45	60	160	28	8	24	15	330	350	185	385	665
YCT160-4B	254	267	45	60	160	28	8	24	15	330	350	185	385	665
YCT180-4A	279	305	45	60	180	28	8	24	15	365	385	195	430	700
YCT200-4A	318	356	50	80	200	38	10	33	19	410	430	235	485	820
YCT200-4B	318	356	50	80	200	38	10	33	19	410	430	235	485	860
YCT225-4A	356	406	56	110	225	42	12	37	19	465	485	270	545	980
YCT225-4B	356	406	56	110	225	42	12	37	19	465	485	270	545	1025
YCT250-4A	406	457	63	110	250	48	14	42.5	24	520	540	295	595	1130
YCT250-4B	406	457	63	110	250	48	14	42.5	24	520	540	295	595	1170
YCT280-4A	457	508	70	110	280	55	16	49	24	575	595	320	665	1280
YCT315-4A	508	560	89	140	315	60	18	53	28	645	670	345	770	1400
YCT315-4B	508	560	89	140	315	60	18	53	28	645	670	345	770	1425
YCT355-4A	610	630	108	140	355	65	18	58	28	755	780	390	890	1550
YCT355-4B	610	630	108	140	355	75	20	67.5	28	755	780	420	890	1630
YCT355-4C	610	630	108	140	355	75	20	67.5	28	755	780	420	890	1680

外形及安装尺寸 Dimensions

mm

YCTL

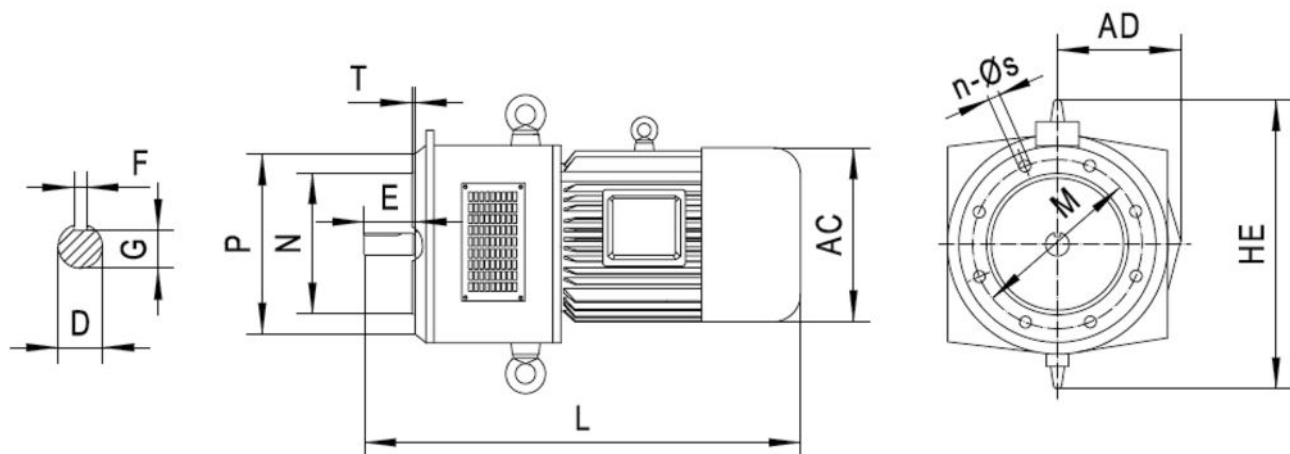

型号 Type	安装尺寸 Mounting Dimensions										外形尺寸 Overall Dimensions			
	D	E	F	G	M	N	P	n	S	T	AC/2	AD	HE	L
YCTL112-4A	19	40	6	15.5	215	180	250	4	15	4	125	150	333	515
YCTL112-4B	19	40	6	15.5	215	180	250	4	15	4	125	150	333	515
YCTL132-4A	24	50	8	20	215	180	250	6	15	4	142	155	391	580
YCTL132-4B	24	50	8	20	215	180	250	6	15	4	142	155	391	580
YCTL160-4A	28	60	8	24	265	230	300	6	15	4	165	185	445	620
YCTL160-4B	28	60	8	24	265	230	300	6	15	4	165	185	445	665
YCTL180-4A	28	60	8	24	265	230	300	6	15	5	180	190	485	670
YCTL200-4A	38	80	10	33	300	250	350	6	19	5	205	210	530	840
YCTL200-4B	38	80	10	33	300	250	350	6	19	5	205	210	530	840
YCTL225-4A	42	110	12	37	350	300	400	6	19	5	225	255	582	970
YCTL225-4B	42	110	12	37	350	300	400	6	19	5	225	255	582	1015
YCTL250-4A	48	110	14	42.5	400	350	450	8	19	5	250	285	642	1130
YCTL250-4B	48	110	14	42.5	400	350	450	8	19	5	250	285	642	1170
YCTL280-4A	55	110	16	49	450	400	500	8	19	5	286	320	740	1270