

YBF2 系列风机用隔爆型三相异步电动机

YBF2 Series Explosion-proof Motors Special for Blower



机座号 80~355

功率 0.18~315kW

防护等级 IP55

能效等级 IEC(1级)

适用于: 含有甲烷等气体或煤尘的煤矿井下(非采掘工作面)(Ex d I)及工厂(Ex d II AT4、d II BT4)含有 II 类 A、B 级 T1~T4 组的可燃性气体或蒸汽与空气形成的爆炸性混合物的场所。

Applications: Ideal for the coal mine where methane and coal dust may be present (Ex d I) and dangerous explosion areas (Ex d II AT4、d II BT4) in the plant with the class II A, II B and temperature T1~T4 flammable gas.

特点: 防爆标志为 Exd I、Exd II AT4、Exd II BT4, I 类的最高表面温度不超过 150°C(当电机表面可能堆积煤尘时),不超过 450°C(当电机表面不会堆积或采取措施可以防止堆积煤尘时); II 类的最高表面温度应不超过: T1 (450°C)、T2 (300°C)、T3 (200°C)、T4 (135°C); 接线盒可分别制成三个或六个出线端子,适用于橡胶套电缆(或塑料电缆)和钢管布线两种结构。

Features: all ratings Class I, Class II A & II B and Group T4, Cast iron conduit-box with three or six terminals for rubber jacket cable and steel conduit entry.

环境温度: 环境温度为 -15°C~35°C(煤矿井下)或 -15°C~40°C(工厂)

Ambient temperature: -15°C~35°C in coal mine and -15°C~40°C in plant.

额定电压: 380V、660V、380/660V.

性能数据 Performance Data

380V 50Hz

型号 Type	功率 kW	额定电流 A	转速 r/min	效率 Eff.%	功率因数 P.F	堵转转矩 额定转矩 $\frac{T_{st}}{T_N}$	堵转电流 额定电流 $\frac{I_{st}}{I_N}$	最大转矩 额定转矩 $\frac{T_{max}}{T_N}$
同步转速 3000 r/min								
YBF2-80M1-2	0.75	1.8	2845	75.0	0.83	2.2	6.0	2.3
YBF2-80M2-2	1.1	2.6	2845	78.0	0.84	2.2	6.0	2.3
YBF2-90S-2	1.5	3.4	2840	79.0	0.84	2.2	7.0	2.3
YBF2-90L-2	2.2	4.9	2840	81.0	0.85	2.2	7.0	2.3
YBF2-100L-2	3	6.3	2860	83.0	0.88	2.2	7.0	2.3
YBF2-112M-2	4	8.1	2880	85.0	0.88	2.2	7.0	2.3
YBF2-132S1-2	5.5	11.0	2900	86.0	0.88	2.2	7.5	2.3
YBF2-132S2-2	7.5	14.9	2900	87.0	0.88	2.2	7.5	2.3
YBF2-160M1-2	11	21.3	2930	88.4	0.88	2.2	7.5	2.4
YBF2-160M2-2	15	28.8	2930	89.4	0.89	2.2	7.5	2.4
YBF2-160L-2	18.5	34.7	2930	90.0	0.89	2.2	7.5	2.4
YBF2-180M-2	22	41.0	2940	90.5	0.90	2.0	7.5	2.3
YBF2-200L1-2	30	55.5	2950	91.4	0.90	2.0	7.5	2.4
YBF2-200L2-2	37	67.9	2950	92.0	0.90	2.0	7.5	2.4
YBF2-225M-2	45	82.3	2960	92.5	0.90	2.0	7.5	2.3
YBF2-250M-2	55	100	2965	93.0	0.90	2.1	7.5	2.3

性能数据 Performance Data
380V 50Hz

型号 Type	功率 kW	额定电流 Current A	转速 r/min	效率 Eff. $\eta\%$	功率因数 Power Factor $\cos\Phi$	堵转转矩 额定转矩 $\frac{T_{st}}{T_N}$	堵转电流 额定电流 $\frac{I_{st}}{I_N}$	最大转矩 额定转矩 $\frac{T_{max}}{T_N}$
同步转速 3000 r/min								
YBF2-280S-2	75	135	2970	93.6	0.91	2.0	7.5	2.3
YBF2-280M-2	90	160	2970	93.9	0.91	2.1	7.5	2.3
YBF2-315S-2	110	195	2975	94.0	0.91	1.8	7.0	2.2
YBF2-315M-2	132	233	2975	94.5	0.91	1.8	7.0	2.2
YBF2-315L1-2	160	279	2975	94.6	0.91	1.8	7.0	2.2
YBF2-315L2-2	200	348	2975	94.8	0.91	1.8	7.0	2.2
YBF2-355S1-2	185	323	2980	94.6	0.91	1.8	7.0	2.2
YBF2-355S2-2	200	348	2980	94.8	0.92	1.8	7.0	2.2
YBF2-355M1-2	220	383	2980	94.8	0.92	1.6	7.0	2.2
YBF2-355M2-2	250	433	2980	95.2	0.92	1.6	7.0	2.2
YBF2-355L1-2	280	485	2980	95.2	0.92	1.6	7.0	2.2
YBF2-355L2-2	315	544	2980	95.4	0.92	1.6	7.0	2.2
同步转速 1500 r/min								
YBF2-80M1-4	0.55	1.6	1390	71.0	0.75	2.4	5.0	2.3
YBF2-80M2-4	0.75	2.0	1390	73.0	0.77	2.4	5.0	2.3
YBF2-90S-4	1.1	2.9	1390	76.2	0.77	2.3	6.0	2.3
YBF2-90L-4	1.5	3.7	1390	78.5	0.79	2.3	6.0	2.3
YBF2-100L1-4	2.2	5.2	1410	81.0	0.81	2.3	6.0	2.4
YBF2-100L2-4	3	6.8	1410	82.6	0.82	2.3	6.0	2.4
YBF2-112M-4	4	8.8	1440	84.2	0.82	2.3	6.0	2.4
YBF2-132S-4	5.5	11.8	1440	86.0	0.84	2.3	7.0	2.4
YBF2-132M-4	7.5	15.6	1440	87.0	0.85	2.3	7.0	2.4
YBF2-160M-4	11	22.3	1460	88.4	0.85	2.2	7.0	2.4
YBF2-160L-4	15	30.1	1460	89.4	0.85	2.2	7.0	2.4
YBF2-180M-4	18.5	36.1	1470	90.5	0.85	2.2	7.0	2.3
YBF2-180L-4	22	42.7	1470	91.2	0.85	2.2	7.0	2.3
YBF2-200L-4	30	57.6	1470	92.0	0.86	2.2	7.2	2.4
YBF2-225S-4	37	69.9	1475	92.5	0.87	2.2	7.2	2.4
YBF2-225M-4	45	84.7	1475	92.8	0.87	2.2	7.2	2.4
YBF2-250M-4	55	103	1480	93.0	0.87	2.2	7.2	2.4
YBF2-280S-4	75	140	1480	93.8	0.87	2.2	7.2	2.4
YBF2-280M-4	90	167	1480	94.2	0.87	2.2	7.2	2.4
YBF2-315S-4	110	201	1480	94.5	0.88	2.1	7.0	2.2
YBF2-315M-4	132	240	1480	94.8	0.88	2.1	7.0	2.2
YBF2-315L1-4	160	288	1480	94.9	0.89	2.1	7.0	2.2
YBF2-315L2-4	200	359	1480	94.9	0.89	2.1	7.0	2.2
YBF2-355S1-4	185	330	1490	94.9	0.89	2.1	7.0	2.2
YBF2-355S2-4	200	356	1490	94.9	0.89	2.1	7.0	2.2
YBF2-355M1-4	220	443	1490	94.9	0.90	2.1	7.0	2.2
YBF2-355M2-4	250	442	1490	95.2	0.90	2.1	7.0	2.2
YBF2-355L1-4	280	495	1490	95.2	0.90	2.1	7.0	2.2
YBF2-355L2-4	315	556	1490	95.2	0.90	2.1	7.0	2.2
同步转速 1000 r/min								
YBF2-80M1-6	0.37	1.3	850	63.0	0.70	1.9	4.0	2.1
YBF2-80M2-6	0.55	1.8	885	66.0	0.72	1.9	4.0	2.1
YBF2-90S-6	0.75	2.3	910	69.0	0.72	2.1	4.0	2.1

性能数据 Performance Data
380V 50Hz

型号 Type	功率 kW	额定电流 Current A	转速 r/min	效率 Eff. $\eta\%$	功率因数 Power Factor $\cos\Phi$	堵转转矩 额定转矩 $\frac{T_{st}}{T_N}$	堵转电流 额定电流 $\frac{I_{st}}{I_N}$	最大转矩 额定转矩 $\frac{T_{max}}{T_N}$
同步转速 1000 r/min								
YBF2-90L-6	1.1	3.2	910	73.0	0.73	2.1	5.0	2.1
YBF2-100L-6	1.5	3.9	920	76.0	0.76	2.1	5.0	2.1
YBF2-112M-6	2.2	5.6	935	79.0	0.76	2.1	5.0	2.1
YBF2-132S-6	3	7.4	960	81.0	0.77	2.1	6.0	2.4
YBF2-132M1-6	4	9.8	960	83.0	0.78	2.1	6.0	2.4
YBF2-132M2-6	5.5	12.9	965	85.0	0.78	2.1	6.5	2.4
YBF2-160M-6	7.5	17.2	970	86.0	0.79	2.1	6.5	2.4
YBF2-160L-6	11	24.5	970	87.5	0.79	2.1	6.5	2.4
YBF2-180L-6	15	31.6	970	89.0	0.81	2.1	7.0	2.1
YBF2-200L1-6	18.5	38.6	980	90.0	0.83	2.2	7.0	2.4
YBF2-200L2-6	22	44.7	980	90.0	0.83	2.2	7.0	2.4
YBF2-225M-6	30	59.3	980	92.0	0.86	2.1	7.0	2.4
YBF2-250M-6	37	71.1	980	92.0	0.86	2.1	7.0	2.4
YBF2-280S-6	45	85.9	980	92.5	0.86	2.1	7.0	2.4
YBF2-280M-6	55	105	980	92.8	0.86	2.1	7.0	2.3
YBF2-315S-6	75	142	985	93.5	0.86	2.0	7.0	2.0
YBF2-315M-6	90	170	985	93.8	0.86	2.0	7.0	2.0
YBF2-315L1-6	110	207	985	94.0	0.86	2.0	7.0	2.0
YBF2-315L2-6	132	245	985	94.2	0.87	2.0	7.0	2.0
YBF2-355S-6	160	292	990	94.5	0.88	1.9	7.0	2.0
YBF2-355M1-6	185	338	990	94.5	0.88	1.9	7.0	2.0
YBF2-355M2-6	200	365	990	94.5	0.88	1.9	7.0	2.0
YBF2-355L1-6	220	401	990	94.5	0.88	1.9	7.0	2.0
YBF2-355L2-6	250	455	990	94.5	0.88	1.9	7.0	2.0
同步转速 750 r/min								
YBF2-80M1-8	0.18	0.88	645	52.0	0.61	1.8	3.3	1.9
YBF2-80M2-8	0.25	1.15	645	55.0	0.61	1.8	3.3	1.9
YBF2-90S-8	0.37	1.49	670	63.0	0.62	1.8	4.0	2.0
YBF2-90L-8	0.55	2.17	670	64.0	0.63	1.8	4.0	2.0
YBF2-100L1-8	0.75	2.4	680	71.0	0.68	1.8	4.0	2.0
YBF2-100L2-8	1.1	3.4	680	73.0	0.69	1.8	4.0	2.0
YBF2-112M-8	1.5	4.4	690	75.0	0.69	1.8	4.0	2.0
YBF2-132S-8	2.2	6.0	705	79.0	0.73	1.8	5.5	2.2
YBF2-132M-8	3	7.9	705	81.0	0.73	1.8	5.5	2.2
YBF2-160M1-8	4	10.3	720	81.0	0.73	1.9	6.0	2.2
YBF2-160M2-8	5.5	13.6	720	83.0	0.75	1.9	6.0	2.2
YBF2-160L-8	7.5	17.8	720	85.0	0.76	1.9	6.0	2.2
YBF2-180L-8	11	25.1	730	87.0	0.76	1.9	6.0	2.2
YBF2-200L-8	15	34.1	730	89.0	0.76	2.0	6.5	2.2
YBF2-225S-8	18.5	41.1	730	90.0	0.78	2.0	6.5	2.2
YBF2-225M-8	22	47.4	730	90.5	0.78	2.0	6.5	2.2
YBF2-250M-8	30	63.4	735	91.0	0.79	1.9	6.5	2.0
YBF2-280S-8	37	77.8	735	91.5	0.79	1.8	6.0	2.0
YBF2-280M-8	45	94.1	735	92.0	0.79	1.8	6.0	2.0
YBF2-315S-8	55	111	735	92.8	0.81	1.8	6.5	2.0

性能数据 Performance Data
380V 50Hz

型号 Type	功率 kW	额定电流 Current A	转速 r/min	效率 Eff. $\eta\%$	功率因数 Power Factor $\cos\Phi$	堵转转矩 额定转矩 $\frac{T_{st}}{T_N}$	堵转电流 额定电流 $\frac{I_{st}}{I_N}$	最大转矩 额定转矩 $\frac{T_{max}}{T_N}$
同步转速 750 r/min								
YBF2-315M-8	75	151	735	93.5	0.81	1.8	6.5	2.0
YBF2-315L1-8	90	178	735	93.8	0.82	1.8	6.5	2.0
YBF2-315L2-8	110	217	735	94.0	0.82	1.8	6.5	2.0
YBF2-355S-8	132	261	740	93.7	0.82	1.8	6.5	2.0
YBF2-355M-8	160	315	740	94.2	0.82	1.8	6.5	2.0
YBF2-355L1-8	185	362	740	94.2	0.82	1.8	6.5	2.0
YBF2-355L2-8	200	387	740	94.5	0.83	1.8	6.5	2.0
同步转速 600 r/min								
YBF2-315S-10	45	99.6	590	91.5	0.75	1.5	6.2	2.0
YBF2-315M-10	55	121	590	92.0	0.75	1.5	6.2	2.0
YBF2-315L1-10	75	162	590	92.5	0.76	1.5	6.2	2.0
YBF2-315L2-10	90	191	590	93.0	0.77	1.5	6.2	2.0
YBF2-355S-10	90	191	590	93.0	0.77	1.5	6.2	2.0
YBF2-355M1-10	110	230	590	93.2	0.78	1.3	6.0	2.0
YBF2-355M2-10	132	275	590	93.5	0.78	1.3	6.0	2.0
YBF2-355L1-10	160	333	590	93.5	0.78	1.3	6.0	2.0
YBF2-355L2-10	185	385	590	93.5	0.78	1.3	6.0	2.0

常用的安装结构型式，以及适用的机座号见下表

Conventional mounting type and suitable frame size are given in following table (with “√”)

机座号 Frame	基本安装结构			派生的安装形式	
	B3	B30	B35	B14	B34
80~112	√	√	√	√	√
132~160	√	√	√	-	-
180~280	√	-	√	-	-
315~355	√	-	√	-	-

注：“√”表示可以制造生产的结构型式。

外形及安装尺寸 Dimensions

B3 (机座带底脚、端盖无凸缘)

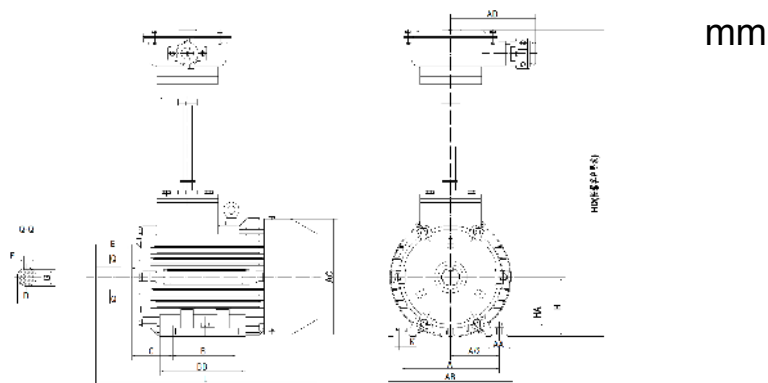

机座号 Frame	极数 Poles	安 装 尺 寸 Mounting Dimension									外 形 尺 寸 Overall Dimension							
		A	B	C	D	E	F	G	H	K	AA	BB	HA	AB	AC	AD	HD	L
80M	2.4.6.8	125	100	50	19	40	6	15.5	80	10	34	130	10	165	165	180	-	330
90S	2.4.6.8	140	100	56	24	50	8	20	90	10	36	130	14	180	180	180	-	360
90L	2.4.6.8	140	125	56	24	50	8	20	90	10	36	155	14	180	180	180	-	385
100L	2.4.6.8	160	140	63	28	60	8	24	100	12	40	176	14	200	205	180	-	440
112M	2.4.6.8	190	140	70	28	60	8	24	112	12	50	180	16	245	230	200	-	460
132S	2.4.6.8	216	140	89	38	80	10	33	132	12	60	190	18	280	270	200	-	510
132M	2.4.6.8	216	178	89	38	80	10	33	132	12	60	230	18	280	270	200	-	550
160M	2.4.6.8	254	210	108	42	110	12	37	160	15	70	258	21	330	325	220	-	670
160L	2.4.6.8	254	254	108	42	110	12	37	160	15	70	302	21	330	325	220	-	710
180M	2.4.6.8	279	241	121	48	110	14	42.5	180	15	70	311	22	355	360	220	-	730
180L	2.4.6.8	279	279	121	48	110	14	42.5	180	15	70	349	22	355	360	220	-	750
200L	2.4.6.8	318	305	133	55	110	16	49	200	19	70	366	25	390	400	250	-	805
225S	4.8	356	286	149	60	140	18	53	225	19	75	355	28	435	450	250	-	865
225M	2	356	311	149	55	110	16	49	225	19	75	388	28	435	450	250	-	860
	60				140	18	53	890										
250M	2	406	349	168	60	140	18	53	250	24	80	420	30	490	500	300	-	945
	65				140	18	58											
280S	2	457	368	190	65	140	18	58	280	24	85	438	35	545	560	300	-	1010
	75				140	20	67.5											
280M	2	457	419	190	65	140	18	58	280	24	85	489	35	545	560	300	-	1060
	75				140	20	67.5											
315S	2	508	406	216	65	140	18	58	315	28	120	570	45	640	630	400	-	1320
	80				170	22	71	1350										
315M	2	508	457	216	65	140	18	58	315	28	120	680	45	640	630	400	-	1350
	80				170	22	71	1380										
315L	2	508	508	216	65	140	18	58	315	28	120	680	45	640	630	400	-	1490
	80				170	22	71	1520										
355S	2	610	500	254	75	140	20	67.5	355	28	116	800	50	740	750	500	-	1570
	95				170	25	86											
355M	2	610	560	254	75	140	20	67.5	355	28	116	800	50	740	750	500	-	1650
	95				170	25	86											
355L	2	610	630	254	75	140	20	67.5	355	28	116	800	50	740	750	500	-	1750
	95				170	25	86											

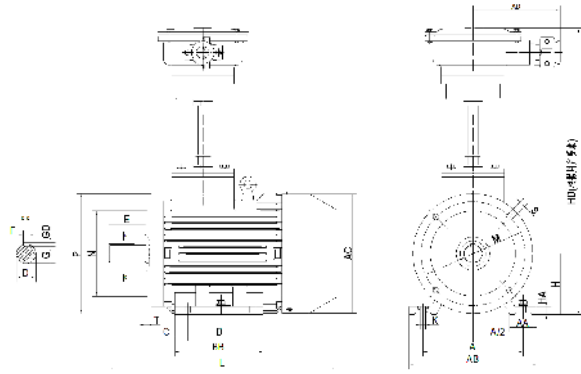
B35 (机座带底脚、端盖有凸缘)

机座号 Frame	极数 Poles	安 装 尺 寸 Mounting Dimension														外形尺寸 Overall Dimension									
		A	B	C	D	E	F	G	H	K	M	N	P	R	S	T	AA	BB	HA	AB	AC	AD	HD	H	L
80M	2.4.6.8	125	100	50	19	40	6	15.5	80	10	165	130	200	0	4-Φ12	3.5	34	130	10	165	165	180	-	460	330
90S	2.4.6.8	140	100	56	24	50	8	20	90	10	165	130	200	0	4-Φ12	3.5	36	130	14	180	180	180	-	570	360
90L	2.4.6.8	140	125	56	24	50	8	20	90	10	165	130	200	0	4-Φ12	3.5	36	155	14	180	180	180	-	570	385
100L	2.4.6.8	160	140	63	28	60	8	24	100	12	215	180	250	0	4-Φ15	4	40	176	14	200	205	180	-	580	440
112M	2.4.6.8	190	140	70	28	60	8	24	112	12	215	180	250	0	4-Φ15	4	50	180	16	245	230	200	-	555	460
132S	2.4.6.8	216	140	89	38	80	10	33	132	12	265	230	300	0	4-Φ15	4	60	190	18	280	270	200	-	640	510
132M	2.4.6.8	216	178	89	38	80	10	33	132	12	265	230	300	0	4-Φ15	4	60	230	18	280	270	200	-	640	550
160M	2.4.6.8	254	210	108	42	110	12	37	160	15	300	250	350	0	4-Φ19	5	70	258	21	330	325	220	-	830	670
160L	2.4.6.8	254	254	108	42	110	12	37	160	15	300	250	350	0	4-Φ19	5	70	302	21	330	325	220	-	830	710
180M	2.4.6.8	279	241	121	48	110	14	42.5	180	15	300	250	350	0	4-Φ19	5	70	311	22	355	360	220	-	860	730
180L	2.4.6.8	279	279	121	48	110	14	42.5	180	15	300	250	350	0	4-Φ19	5	70	349	22	355	360	220	-	860	750
200L	2.4.6.8	318	305	133	55	110	16	49	200	19	350	300	400	0	4-Φ19	5	70	366	25	390	400	250	-	800	805
225S	4.8	356	286	149	60	140	18	53	225	19	400	350	450	0	8-Φ19	5	75	355	28	435	450	250	-	970	865
225M	2	356	311	149	55	110	16	49	225	19	400	350	450	0	8-Φ19	5	75	388	28	435	450	250	-	970	860
	4.6.8				60	140	18	53																	890
250M	2	406	349	168	60	140	18	53	250	24	500	450	550	0	8-Φ19	5	80	420	30	490	500	300	-	1010	945
	4.6.8				65	140	18	58																	
280S	2	457	368	190	65	140	18	58	280	24	500	450	550	0	8-Φ19	5	85	438	35	545	565	300	-	1070	1010
	4.6.8				75	140	20	67.5																	
280M	2	457	419	190	65	140	18	58	280	24	500	450	550	0	8-Φ19	5	85	489	35	545	565	300	-	1070	1060
	4.6.8				75	140	20	67.5																	
315S	2	508	406	216	65	140	18	58	315	28	600	550	660	0	8-Φ24	6	120	570	45	640	630	400	-	950	1320
	4.6.8.10				80	170	22	71																	1350
315M	2	508	457	216	65	140	18	58	315	28	600	550	660	0	8-Φ24	6	120	680	45	640	630	400	-	950	1350
	4.6.8.10				80	170	22	71																	1380
315L	2	508	508	216	65	140	18	58	315	28	600	550	660	0	8-Φ24	6	120	680	45	640	630	400	-	950	1490
	4.6.8.10				80	170	22	71																	1520
355S	2	610	500	254	75	140	20	67.5	355	28	740	680	800	0	8-Φ24	6	116	800	50	740	750	500	-	1600	1570
	4.6.8.10				95	170	25	86																	
355M	2	610	560	254	75	140	20	67.5	355	28	740	680	800	0	8-Φ24	6	116	800	50	740	750	500	-	1600	1650
	4.6.8.10				95	170	25	86																	
355L	2	610	630	254	75	140	20	67.5	355	28	740	680	800	0	8-Φ24	6	116	800	50	740	750	500	-	1600	1750
	4.6.8.10				95	170	25	86																	

注： HD 尺寸用户可以根据需要自行选取