

YB3 系列隔爆型三相异步电动机

YB3 Series Explosion-proof Induction Motors

机座号 80~355 功率 0.18~315kW
 防护等级 IP55
 能效等级 中国 GB18613-2012 3级 (IEC 2级)



适用于: 含有甲烷等气体或煤尘的煤矿井下(非采掘工作面)(Ex d I)及工厂(Ex d IIA T4、d IIB T4)含有II类 A、B级 T1~T4 组的可燃性气体或蒸汽与空气形成的爆炸性混合物的场所。

Applications: Ideal for the coal mine where methane and coal dust may be present (Ex d I) and dangerous explosion areas (Ex d IIA T4、d IIB T4) in the plant with the class II A, IIB and temperature T1~T4 flammable gas.

特点: 防爆标志为 Exd I、Exd IIA T4、Exd IIB T4, I类的最高表面温度不超过150℃(当电机表面可能堆积煤尘时),不超过450℃(当电机表面不会堆积或采取措施可以防止堆积煤尘时); II类的最高表面温度应不超过: T1(450℃)、T2(300℃)、T3(200℃)、T4(135℃); 接线盒可分别制成三个或六个出线端子,适用于橡胶套电缆(或塑料电缆)和钢管布线两种结构。

Features: all ratings Class I, Class IIA & IIB and Group T4, Cast iron conduit-box with three or six terminals for rubber jacket cable and steel conduit entry.

环境温度: 环境温度为-15℃~35℃(煤矿井下)或-15℃~40℃(工厂)

Ambient temperature: -15℃~35℃ in coal mine and -15℃~40℃ in plant.

额定电压: 380V、660V、380/660V

性能数据 Performance Data

380V 50Hz

型号 Type	功率 kW	额定电流 Current A	转速 r/min	效率 Eff. η%	功率因数 P.F	额定 转矩 N.m	堵转转矩 额定转矩 $\frac{T_{st}}{T_N}$	堵转电流 额定电流 $\frac{I_{st}}{I_N}$	最大转矩 额定转矩 $\frac{T_{max}}{T_N}$	噪声 dB(A)
同步转速 3000r/min										
YB3-80M1-2	0.75	1.8	2855	77.4	0.83	2.5	2.3	6.8	2.3	67
YB3-80M2-2	1.1	2.5	2870	79.6	0.83	3.7	2.3	7.3	2.3	67
YB3-90S-2	1.5	3.3	2865	81.3	0.84	5.0	2.3	7.6	2.3	72
YB3-90L-2	2.2	4.7	2870	83.2	0.85	7.3	2.3	7.8	2.3	72
YB3-100L-2	3	6.2	2875	84.6	0.87	10.0	2.3	8.1	2.3	76
YB3-112M-2	4	8.0	2910	85.8	0.88	13.1	2.3	8.3	2.3	77
YB3-132S1-2	5.5	10.9	2935	87.0	0.88	17.9	2.2	8	2.3	80
YB3-132S2-2	7.5	14.5	2930	88.1	0.89	24.4	2.2	7.8	2.3	80
YB3-160M1-2	11	21.0	2950	89.4	0.89	35.6	2.2	7.9	2.3	86
YB3-160M2-2	15	28.4	2945	90.3	0.89	48.6	2.2	8	2.3	86
YB3-160L-2	18.5	34.7	2940	90.9	0.89	60.1	2.2	8.1	2.3	86

性能数据 Performance Data

380V 50Hz

型号 Type	功率 kW	额定电流 Current A	转速 r/min	效率 Eff. $\eta\%$	功率因数 P.F	额定 转矩 N.m	堵转转矩 额定转矩 $\frac{Tst}{TN}$	堵转电流 额定电流 $\frac{Ist}{TN}$	最大转矩 额定转矩 $\frac{Tmax}{TN}$	噪声 dB(A)
同步转速 3000r/min										
YB3-180M-2	22	41.1	2950	91.3	0.89	71.2	2.2	8.2	2.3	88
YB3-200L1-2	30	55.7	2960	92.0	0.89	96.8	2.2	7.5	2.3	90
YB3-200L2-2	37	68.3	2960	92.5	0.89	119	2.2	7.5	2.3	90
YB3-225M-2	45	82.7	2965	92.9	0.89	145	2.2	7.6	2.3	92
YB3-250M-2	55	101	2970	93.2	0.89	177	2.2	7.6	2.3	93
YB3-280S-2	75	137	2975	93.8	0.89	241	2	6.9	2.3	94
YB3-280M-2	90	163	2970	94.1	0.89	289	2	7	2.3	94
YB3-315S-2	110	197	2975	94.3	0.9	353	2	7.1	2.2	96
YB3-315M-2	132	236	2975	94.6	0.9	424	2	7.1	2.2	96
YB3-315L1-2	160	282	2975	94.8	0.91	514	2	7.1	2.2	98
YB3-315L2-2	200	352	2975	95.0	0.91	642	2	7.1	2.2	98
YB3-355S1-2	185	326	2980	94.8	0.91	593	2	7.1	2.2	98
YB3-355S2-2	200	352	2980	95.0	0.91	641	2	7.1	2.2	98
YB3-355M1-2	220	387	2980	95.0	0.91	705	2	7.1	2.2	100
YB3-355M2-2	250	439	2980	95.0	0.91	801	2	7.1	2.2	100
YB3-355L1-2	280	492	2980	95.0	0.91	897	2	7.1	2.2	100
YB3-355L2-2	315	554	2980	95.0	0.91	1009	2	7.1	2.2	100
同步转速 1500r/min										
YB3-80M1-4	0.55	1.4	1430	79.0	0.75	3.7	2.3	6.3	2.3	58
YB3-80M2-4	0.75	1.9	1425	79.6	0.75	5.0	2.3	6.5	2.3	58
YB3-90S-4	1.1	2.7	1420	81.4	0.75	7.4	2.3	6.6	2.3	61
YB3-90L-4	1.5	3.7	1420	82.8	0.75	10.1	2.3	6.9	2.3	61
YB3-100L1-4	2.2	4.9	1430	84.3	0.81	14.7	2.3	7.5	2.3	64
YB3-100L2-4	3	6.5	1430	85.5	0.82	20.0	2.3	7.6	2.3	64
YB3-112M-4	4	8.6	1450	86.6	0.82	26.3	2.3	7.7	2.3	65
YB3-132S-4	5.5	11.6	1465	87.7	0.82	35.9	2	7.5	2.3	71
YB3-132M-4	7.5	15.5	1465	88.7	0.83	48.9	2	7.4	2.3	71
YB3-160M-4	11	21.9	1470	89.8	0.85	71.5	2.2	7.5	2.3	75
YB3-160L-4	15	29.3	1470	90.6	0.86	97.4	2.2	7.5	2.3	75
YB3-180M-4	18.5	35.8	1470	91.2	0.86	120	2.2	7.7	2.3	76
YB3-180L-4	22	42.4	1465	91.6	0.86	143	2.2	7.8	2.3	76
YB3-200L-4	30	57.4	1475	92.3	0.86	194	2.2	7.2	2.3	79
YB3-225S-4	37	70.5	1480	92.7	0.86	239	2.2	7.3	2.3	81
YB3-225M-4	45	85.4	1480	93.1	0.86	290	2.2	7.4	2.3	81
YB3-250M-4	55	104	1485	93.5	0.86	354	2.2	7.4	2.3	83
YB3-280S-4	75	138	1490	94.0	0.88	481	2.2	6.7	2.3	86
YB3-280M-4	90	165	1485	94.2	0.88	579	2.2	6.9	2.3	86
YB3-315S-4	110	201	1485	94.5	0.88	707	2.2	6.9	2.2	93

性能数据 Performance Data

380V 50Hz

型号 Type	功率 kW	额定电流 Current A	转速 r/min	效率 Eff. $\eta\%$	功率因 数 P.F	额定 转矩 N.m	堵转转矩 额定转矩 $\frac{Tst}{TN}$	堵转电流 额定电流 $\frac{Ist}{TN}$	最大转矩 额定转矩 $\frac{Tmax}{TN}$	噪声 dB(A)
同步转速 1500r/min										
YB3-315M-4	132	241	1485	94.7	0.88	849	2.2	6.9	2.2	93
YB3-315L1-4	160	288	1485	94.9	0.89	1029	2.2	6.9	2.2	94
YB3-315L2-4	200	359	1485	95.1	0.89	1286	2.2	6.9	2.2	94
YB3-355S1-4	185	333	1490	94.9	0.89	1186	2.2	6.9	2.2	94
YB3-355S2-4	200	359	1490	95.1	0.89	1282	2.2	6.9	2.2	94
YB3-355M1-4	220	391	1490	95.1	0.9	1410	2.2	6.9	2.2	95
YB3-355M-4	250	444	1490	95.1	0.9	1602	2.2	6.9	2.2	95
YB3-355L1-4	280	497	1490	95.1	0.9	1795	2.2	6.9	2.2	95
YB3-355L2-4	315	559	1490	95.1	0.9	2019	2.2	6.9	2.2	95
同步转速 1000 r/min										
YB3-80M1-6	0.37	1.2	910	67	0.7	3.9	1.9	4.7	2.1	54
YB3-80M2-6	0.55	1.7	910	70	0.72	5.8	1.9	4.7	2.1	54
YB3-90S-6	0.75	2.1	935	75.9	0.72	7.7	2.1	5.8	2.1	57
YB3-90L-6	1.1	2.9	935	78.1	0.73	11.2	2.1	5.9	2.1	57
YB3-100L-6	1.5	3.9	945	79.8	0.74	15.2	2.1	6	2.1	61
YB3-112M-6	2.2	5.5	965	81.8	0.74	21.8	2.1	6	2.1	65
YB3-132S-6	3	7.4	975	83.3	0.74	29.4	2	6.2	2.1	69
YB3-132M1-6	4	9.7	975	84.6	0.74	39.2	2	6.8	2.1	69
YB3-132M2-6	5.5	13.0	975	86.0	0.75	53.9	2	7.1	2.1	69
YB3-160M-6	7.5	16.8	975	87.2	0.78	73.5	2.1	6.7	2.1	73
YB3-160L-6	11	23.9	975	88.7	0.79	108	2.1	6.9	2.1	73
YB3-180L-6	15	31.4	980	89.7	0.81	146	2	7.2	2.1	73
YB3-200L1-6	18.5	38.4	980	90.4	0.81	180	2.1	7.2	2.1	76
YB3-200L2-6	22	44.8	980	90.9	0.82	214	2.1	7.3	2.1	76
YB3-225M-6	30	61.4	985	91.7	0.81	291	2	7.1	2.1	76
YB3-250M-6	37	72.6	985	92.2	0.84	359	2.1	7.1	2.1	78
YB3-280S-6	45	85.8	990	92.7	0.86	434	2.1	7.2	2	80
YB3-280M-6	55	104	990	93.1	0.86	531	2.1	7.2	2	80
YB3-315S-6	75	143	990	93.7	0.85	723	2	6.7	2	85
YB3-315M-6	90	173	990	94.0	0.84	868	2	6.7	2	85
YB3-315L1-6	110	209	990	94.3	0.85	1061	2	6.7	2	85
YB3-315L2-6	132	247	990	94.6	0.86	1273	2	6.7	2	85
YB3-355S-6	160	295	990	94.8	0.87	1543	2	6.7	2	92
YB3-355M1-6	185	341	990	94.8	0.87	1785	2	6.7	2	92
YB3-355M2-6	200	368	990	95.0	0.87	1929	2	6.7	2	92
YB3-355L1-6	220	404	990	95.0	0.87	2122	2	6.7	2	92
YB3-355L2-6	250	460	990	95.0	0.87	2412	2	6.7	2	92

性能数据 Performance Data

380V 50Hz

型号 Type	功率 kW	额定电流 Current A	转速 r/min	效率 Eff. $\eta\%$	功率因数 P.F	额定 转矩 N.m	堵转转矩 额定转矩 $\frac{Tst}{TN}$	堵转电流 额定电流 $\frac{Ist}{TN}$	最大转矩 额定转矩 $\frac{Tmax}{TN}$	噪声 dB(A)
同步转速 750r/min										
YB3-80M1-8	0.18	0.9	700	51	0.61	2.5	1.8	3.3	1.9	52
YB3-80M2-8	0.25	1.2	700	54	0.61	3.4	1.8	3.3	1.9	52
YB3-90S-8	0.37	1.5	695	62	0.61	5.1	1.8	4	1.9	56
YB3-90L-8	0.55	2.2	695	63	0.61	7.6	1.8	4	2	56
YB3-100L1-8	0.75	2.4	705	70	0.67	10.2	1.8	4	2	59
YB3-100L2-8	1.1	3.4	705	72	0.69	14.9	1.8	5	2	59
YB3-112M-8	1.5	4.4	715	74	0.70	20.0	1.8	5	2	61
YB3-132S-8	2.2	6.0	730	79	0.71	28.8	1.8	6	2	64
YB3-132M-8	3	7.8	730	80	0.73	39.2	1.8	6	2	64
YB3-160M1-8	4	10.3	725	81	0.73	52.7	1.9	6	2	68
YB3-160M2-8	5.5	13.6	725	83	0.74	72.4	1.9	6	2	68
YB3-160L-8	7.5	17.8	730	85.5	0.75	98.1	1.9	6	2	68
YB3-180L-8	11	25.5	725	87.5	0.75	145	2	6.5	2	70
YB3-200L-8	15	34.1	730	88.0	0.76	196	2	6.6	2	73
YB3-225S-8	18.5	41.1	735	90	0.76	240	1.9	6.6	2	73
YB3-225M-8	22	47.4	735	90.5	0.78	286	1.9	6.6	2	73
YB3-250M-8	30	63.4	735	91.0	0.79	390	1.9	6.5	2	75
YB3-280S-8	37	77.8	740	91.5	0.79	478	1.9	6.6	2	76
YB3-280M-8	45	94.1	740	92	0.79	581	1.9	6.6	2	76
YB3-315S-8	55	111	740	92.8	0.81	710	1.8	6.6	2	82
YB3-315M-8	75	150	740	93.5	0.81	968	1.8	6.2	2	82
YB3-315L1-8	90	178	740	93.8	0.82	1161	1.8	6.4	2	82
YB3-315L2-8	110	217	740	94	0.82	1420	1.8	6.4	2	82
YB3-355S-8	132	261	745	93.7	0.82	1692	1.8	6.4	2	90
YB3-355M-8	160	315	745	94.2	0.82	2051	1.8	6.4	2	90
YB3-355L1-8	185	364	745	94.2	0.82	2371	1.8	6.4	2	90
YB3-355L2-8	200	387	745	94.5	0.83	2564	1.8	6.4	2	90
同步转速 600 r/min										
YB3-315S-10	45	100	590	91.5	0.75	728	1.5	6.2	2	82
YB3-315M-10	55	121	590	92	0.75	890	1.5	6.2	2	82
YB3-315L1-10	75	162	590	92.5	0.76	1214	1.5	5.8	2	82
YB3-315L2-10	90	191	590	93	0.77	1457	1.5	5.9	2	82
YB3-355M1-10	110	230	595	93.2	0.78	1766	1.3	6.0	2	90
YB3-355M2-10	132	275	595	93.5	0.78	2119	1.3	6.0	2	90
YB3-355L1-10	160	333	595	93.5	0.78	2568	1.3	6.0	2	90
YB3-355L2-10	185	385	595	93.5	0.78	2969	1.3	6.0	2	90

外形及安装尺寸 Dimensions

mm

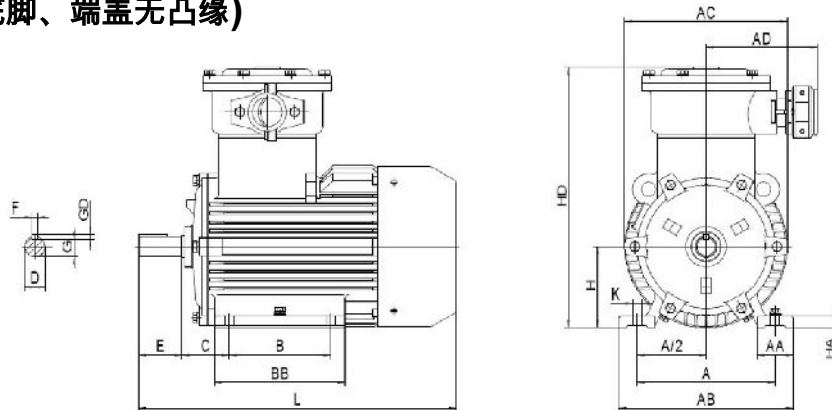
B3 (机座带底脚、端盖无凸缘)

机座 Frame	极数 Poles	安 装 尺 寸 Mounting Dimension									外 形 尺 寸 Overall Dimension										
		A	B	C	D	E	F	G	H	K	AA	BB	HA	AB	AC	AD	HD	L			
80M	2,4,6,8	125	100	50	19	40	6	15.5	80	10	34	150	10	165	165	180	300	330			
90S	2,4,6,8	140	100	56	24	50	8	20	90	10	36	140	14	180	180	185	330	355			
90L			125									165						385			
100L	2,4,6,8	160	140	63	28	60	8	24	100	12	40	190	14	205	210	185	355	435			
112M	2,4,6,8	190		70															112	50	180
132S	2,4,6,8	216	140	89	38	80	10	33	132	12	60	190	18	280	290	205	420	470			
132M			178									230						510			
160M	2,4,6,8	254	210	108	42	110	12	37	160	15	70	253	25	335	330	225	495	730			
160L			254									297						760			
180M	2,4,6,8	279	241	121	48	110	14	42.5	180	15	70	315	22	360	360	225	535	730			
180L			279									350						750			
200L	2,4,6,8	318	305	133	55	110	16	49	200	19	70	366	25	390	400	255	655	815			
225S	4,8	356	286	149	60	140	18	53	225	19	75	355	28	435	450	255	630	855			
225M	2		311		55	110	16	49				388						850			
	4,6,8		60		140	18	53	880													
250M	2	406	349	168	60	140	18	58	250	24	80	420	30	490	500	275	720	940			
	4,6,8				65													58			
280S	2	457	368	190	65	140	18	58	280	24	90	458	35	545	550	285	785	1000			
	4,6,8																	75	20	67.5	
280M	2																	419	65	18	58
	4,6,8	75	20	67.5																	
315S	2	508	406	216	65	140	18	58	315	28	120	570	45	630	630	365	960	1220			
	4,6,8,10																	80	170	22	71
315M	2																	457	65	140	18
	4,6,8,10	80	170	22	71	1360															
315L	2	508	65	140	18	58	80	170	22	71	1330										
	4,6,8,10											80	170	22	71	1360					
355S	2	610	500	254	75	140	20	67.5	355	28	116	636	50	735	720	375	1050	1420			
	4,6,8,10																	95	170	25	86
355M	2																	560	75	140	20
	4,6,8,10	95	170	25	86	1530															
355L	2	630	75	140	20	67.5	95	170	25	86	766	1600									
	4,6,8,10												95	170	25	86	1630				

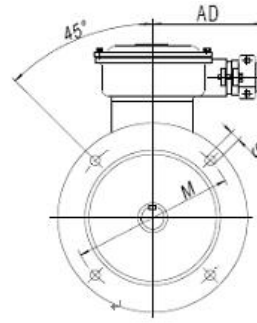
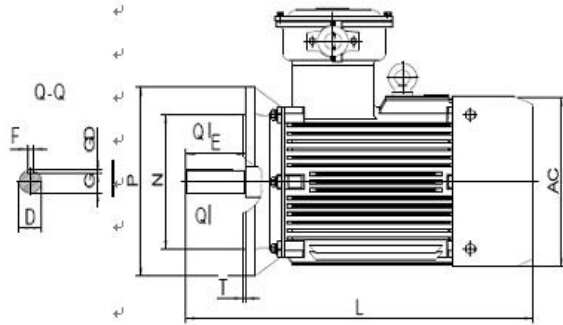
B5 (机座不带底脚、端盖有凸缘)

H80-200mm

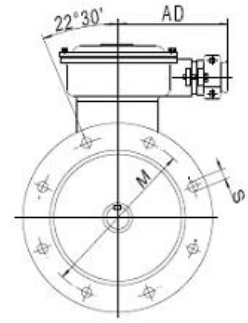

H225-280mm

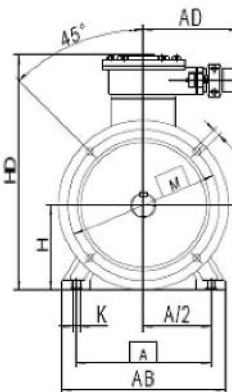
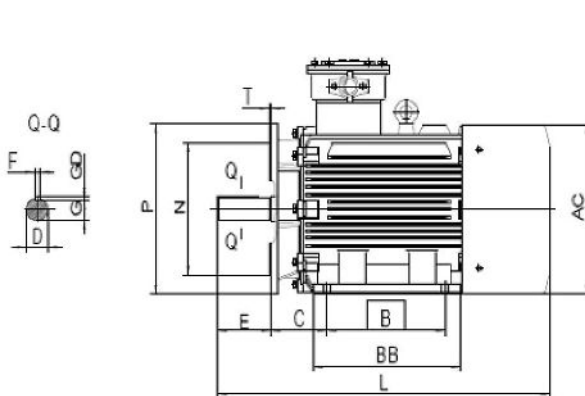
B35 (机座带底脚、端盖有凸缘)

H80-200mm

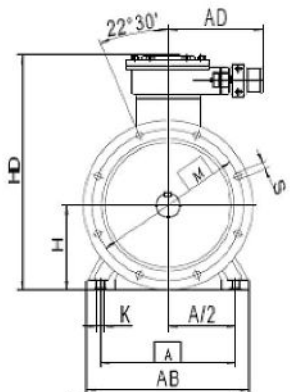

H225-355mm

机座号 Frame	极数 Poles	安装尺寸 Mounting Dimension															外形尺寸 Overall Dimension								
		A	B	C	D	E	F	G	H	K	M	N	P	R	S	T	凸缘孔数	AA	BB	HA	AB	AC	AD	HD	L
80M	2,4,6,8	125	100	50	19	40	6	15.5	80	10	165	130	200	0	12	3.5	4	34	150	10	160	165	175	300	330
90S	2,4,6,8	140	100	56	24	50	8	20	90	10	165	130	200	0	12	3.5	4	36	140	14	176	180	180	330	355
90L			125																165						385
100L	2,4,6,8	160	140	63	28	60	8	24	100	12	215	180	250	0	15	4	4	39	190	14	198	210	180	355	435
112M	2,4,6,8	190	140	70														112	50	180	230	250	360	460	
132S	2,4,6,8	216	140	89	38	80	10	33	132	12	265	230	300	0	15	4	4	60	190	18	276	290	200	420	470
132M			178																230						510
160M	2,4,6,8	254	210	108	42	110	12	37	160	15	300	250	350	0	19	5	4	70	253	25	324	330	220	495	730
160L			254																297						760
180M	2,4,6,8	279	241	121	48	110	14	42.5	180	15	300	250	350	0	19	5	4	70	315	22	349	360	220	535	730
180L			279																350						750
200L	2,4,6,8	318	305	133	55	110	16	49	200	19	350	300	400	0	19	5	4	70	366	25	388	400	250	655	815
225S	4,8	356	286	149	60	140	18	53	225	19	400	350	450	0	19	5	8	75	355	28	431	450	250	630	855
225M	2		55		110	16	49	388											880						
	4,6,8		60		140	18	53																		
250M	2	406	349	168	60	140	18	53	250	24	500	450	550	0	19	5	8	80	420	30	486	500	270	720	940
	4,6,8				65			58																	
280S	2	457	368	190	65	140	18	58	280	24	500	450	550	0	19	5	8	90	458	35	544	550	280	785	1000
	4,6,8				75			20																	
280M	2				419			65																	
	4,6,8	75	20	67.5																					

机座号 Frame	极数 Poles	安 装 尺 寸 Mounting Dimension															外 形 尺 寸 Overall Dimension								
		A	B	C	D	E	F	G	H	K	M	N	P	R	S	T	凸缘 孔数	AA	BB	HA	AB	AC	AD	HD	L
315S	2	508	406	216	65		18	58	315	28	600	550	660	0	24	6	8	120	570	45	628	630	360	960	1210
	4,6,8,10				80	170	22	71																	1250
315M	2	508	457	216	65	140	18	58	315	28	600	550	660	0	24	6	8	120	680	45	628	630	360	960	1330
	4,6,8,10				80	170	22	71																	1360
315L	2	508	457	216	65	140	18	58	315	28	600	550	660	0	24	6	8	120	680	45	628	630	360	960	1330
	4,6,8,10				80	170	22	71																	1360
355S	2	610	500	254	75	140	20	67.5	355	28	740	680	800	0	24	6	8	116	636	50	726	720	370	1050	1420
	4,6,8,10				95	170	25	86																	1450
355M	2	610	560	254	75	140	20	67.5	355	28	740	680	800	0	24	6	8	116	696	50	726	720	370	1050	1500
	4,6,8,10				95	170	25	86																	1530
355L	2	610	560	254	75	140	20	67.5	355	28	740	680	800	0	24	6	8	116	766	50	726	720	370	1050	1600
	4,6,8,10				95	170	25	86																	1630

常用的安装结构型式，以及适用的机座号见下表

Conventional mounting type and suitable frame size are given in following table (with “√”)

机座号 Frame	基本安装结构 Basic Type			派生的安装形式 Derived Type													
	B3	B5	B35	V1	V3	V5	V6	B6	B7	B8	V15	V17	V35	V37	B14	B34	V18
80~112	√	√	√	√	√	√	√	√	√	√	√	√	√	√	√	√	√
132~160	√	√	√	√	√	√	√	√	√	√	√	√	√	√	-	-	-
180~280	√	√	√	√	-	-	-	-	-	-	-	-	-	-	-	-	-
315~355	√	-	√	√	-	-	-	-	-	-	-	-	-	-	-	-	-

注：“√”表示可以制造生产的结构型式。电机订购时，若不作说明的接线盒为顶式。



