

YXL 系列高效率铝机壳三相异步电动机

YXL Series High Efficiency Aluminum Frame Three Phase Induction Motors

一、概述



机座号 63~160

功率 0.12~18.5kW

工作制 S1

冷却方式: IC411

能效等级: 中国 GB18613-2012 3 级 (IE2)

适用于: 一般场所和无特殊要求的机械, 如金属切削机床、泵、风机、运输机械、搅拌机、农业机械、食品机械等。

Applications: General purpose including cutting machines, pumps, fans, conveyors, machines tools of farm duty and food process.

特点: 其外形美观、高效节能, F 级绝缘, 防护等级为 IP55, 电机噪声低、振动小, 运行可靠。

Features: These series motors have many virtues, including beautiful profile, high efficiency and energy saving, class F insulated, the protective class is IP55, low noise, little vibration, running smoothly.

性能数 Performance Data

380V 50Hz

型号 Type	功率 kW	额定 电流 A	转速 r/min	效率 Eff. %	功率 因数 P.F	额定 转矩 N.m	堵转转矩 额定转矩 $\frac{T_{st}}{T_N}$	堵转电流 额定电流 $\frac{I_{st}}{I_N}$	最大转矩 额定转矩 $\frac{T_{max}}{T_N}$	噪声 dB(A)
同步转速 3000 r/min										
YXL63M1-2	0.18	0.53	2720	63.9	0.80	0.63	2.2	5.5	2.2	61
YXL63M2-2	0.25	0.70	2720	67.1	0.81	0.88	2.2	5.5	2.2	61
YXL71M1-2	0.37	1.0	2740	69.0	0.81	1.29	2.2	6.1	2.2	62
YXL71M2-2	0.55	1.4	2740	72.3	0.82	1.92	2.2	6.1	2.2	62
YXL80M1-2	0.75	1.8	2855	77.4	0.82	2.5	2.2	7.0	2.3	62
YXL80M2-2	1.1	2.5	2870	79.6	0.83	3.7	2.2	7.3	2.3	62
YXL90S-2	1.5	3.3	2865	81.3	0.84	5.0	2.2	7.6	2.3	67
YXL90L-2	2.2	4.7	2870	83.2	0.85	7.3	2.2	7.6	2.3	67
YXL100L-2	3	6.2	2875	84.6	0.87	10.0	2.2	7.8	2.3	74
YXL112M-2	4	8.0	2910	85.8	0.88	13.1	2.2	8.3	2.3	77
YXL132S1-2	5.5	10.9	2935	87.0	0.88	17.9	2.0	8.3	2.3	79
YXL132S2-2	7.5	14.5	2930	88.1	0.89	24.4	2.0	7.9	2.3	79
YXL160M1-2	11	21.0	2950	89.4	0.89	35.6	2.0	8.1	2.3	81
YXL160M2-2	15	28.4	2945	90.3	0.89	48.6	2.0	8.1	2.3	81
YXL160L-2	18.5	34.7	2945	90.9	0.89	60.0	2.0	8.2	2.3	81



性能数据 Performance Data

380V 50Hz

型号 Type	功率 kW	额定 电流 A	转速 r/min	效率 Eff. %	功率 因数 P.F	额定 转矩 N.m	堵转转矩 额定转矩 $\frac{T_{st}}{T_N}$	堵转电流 额定电流 $\frac{I_{st}}{I_N}$	最大转矩 额定转矩 $\frac{T_{max}}{T_N}$	噪声 dB(A)
同步转速 1500 r/min										
YXL63M1-4	0.12	0.45	1310	55.8	0.72	0.87	2.1	4.4	2.2	52
YXL63M2-4	0.18	0.64	1310	58.6	0.73	1.31	2.1	4.4	2.2	52
YXL71M1-4	0.25	0.81	1330	63.6	0.74	1.80	2.1	5.2	2.2	55
YXL71M2-4	0.37	1.1	1330	65.3	0.75	2.66	2.1	5.2	2.2	55
YXL80M1-4	0.55	1.4	1430	79.0	0.75	3.7	2.3	6.0	2.3	56
YXL80M2-4	0.75	1.9	1425	79.6	0.76	5.0	2.3	6.6	2.3	56
YXL90S-4	1.1	2.7	1420	81.4	0.77	7.4	2.3	6.8	2.3	59
YXL90L-4	1.5	3.5	1420	82.8	0.78	10.1	2.3	7.0	2.3	59
YXL100L1-4	2.2	5.0	1430	84.3	0.80	14.7	2.3	7.6	2.3	64
YXL100L2-4	3	6.6	1430	85.5	0.81	20.0	2.3	7.6	2.3	64
YXL112M-4	4	8.7	1450	86.6	0.81	26.3	2.2	7.8	2.3	65
YXL132S-4	5.5	11.6	1465	87.7	0.82	35.9	2.0	7.9	2.3	71
YXL132M-4	7.5	15.5	1465	88.7	0.83	48.9	2.0	7.5	2.3	71
YXL160M-4	11	22.4	1470	89.8	0.83	71.5	2.0	7.7	2.3	73
YXL160L-4	15	29.9	1470	90.6	0.84	97.4	2.0	7.8	2.3	73
同步转速 1000 r/min										
YXL71M1-6	0.18	0.76	850	54.6	0.66	2.02	1.9	4.0	2.0	52
YXL71M2-6	0.25	0.97	850	57.4	0.68	2.81	1.9	4.0	2.0	52
YXL80M1-6	0.37	1.2	910	67.0	0.7	3.9	1.9	5.5	2.1	54
YXL80M2-6	0.55	1.7	910	70.0	0.71	5.8	1.9	5.5	2.1	54
YXL90S-6	0.75	2.1	935	75.9	0.71	7.7	2.0	6.0	2.1	57
YXL90L-6	1.1	3.0	935	78.1	0.72	11.2	2.0	6.0	2.1	57
YXL100L-6	1.5	4.0	945	79.8	0.72	15.2	2.0	6.5	2.1	61
YXL112M-6	2.2	5.7	965	81.8	0.72	21.8	2.0	6.6	2.1	65
YXL132S-6	3	7.6	975	83.3	0.72	29.4	1.9	6.8	2.1	69
YXL132M1-6	4	9.7	975	84.6	0.74	39.2	1.9	6.8	2.1	69
YXL132M2-6	5.5	13.0	975	86.0	0.75	53.9	1.9	7.0	2.1	69
YXL160M-6	7.5	16.8	975	87.2	0.78	73.5	2.0	7.0	2.1	70
YXL160L-6	11	23.9	975	88.7	0.79	108	2.0	7.2	2.1	70
同步转速 750 r/min										
YXL80M1-8	0.18	0.8	700	52.8	0.61	2.5	1.8	3.3	1.9	52
YXL80M2-8	0.25	1.1	700	57	0.61	3.4	1.8	3.3	1.9	52
YXL90S-8	0.37	1.4	695	64	0.62	5.1	1.8	4.0	2.0	56
YXL90L-8	0.55	2.0	695	67.5	0.63	7.6	1.8	4.0	2.0	56
YXL100L1-8	0.75	2.3	705	71.5	0.68	10.2	1.8	4.0	2.0	59
YXL100L2-8	1.1	3.3	705	74.5	0.69	14.9	1.8	4.0	2.0	59

性能数据 Performance Data

380V 50Hz

型号 Type	功率 kW	额定 电流 A	转速 r/min	效率 Eff. %	功率 因数 P.F	额定 转矩 N.m	堵转转矩 额定转矩 $\frac{T_{st}}{T_N}$	堵转电流 额定电流 $\frac{I_{st}}{I_N}$	最大转矩 额定转矩 $\frac{T_{max}}{T_N}$	噪声 dB(A)
同步转速 750 r/min										
YXL112M-8	1.5	4.4	715	75.4	0.69	20.0	1.8	4.0	2.0	61
YXL132S-8	2.2	6.0	730	78.2	0.71	28.8	1.8	5.5	2.2	64
YXL132M-8	3	7.7	730	80.6	0.73	39.2	1.8	5.5	2.2	64
YXL160M1-8	4	10.1	725	82.7	0.73	52.7	1.9	6.0	2.2	68
YXL160M2-8	5.5	13.4	725	84.3	0.74	72.4	1.9	6.0	2.2	68
YXL160L-8	7.5	17.7	730	85.8	0.75	98.1	1.9	6.0	2.2	68

外形及安装尺 Dimensions

mm

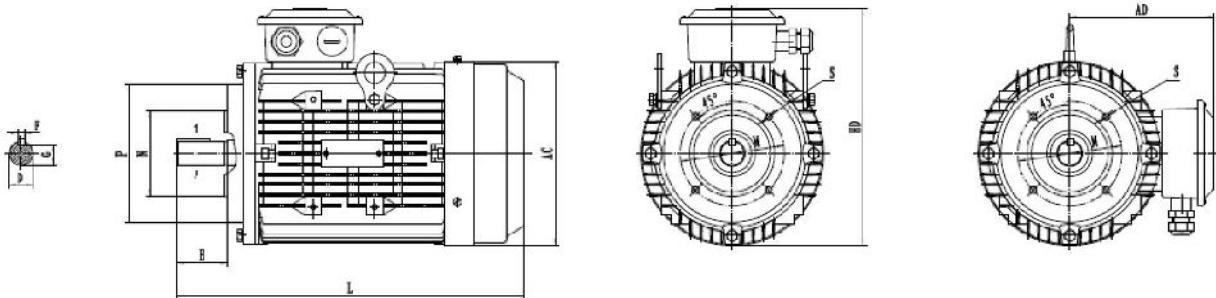
B14 (机座无底脚、端盖上有小凸缘)

机座号 Frame	极数 Poles	安 装 尺 寸 及 公 差 Mounting Dimension										外 形 尺 寸 Overall Dimension			
		D	E	F	G	M	N	P	R	S	T	AC	AD	HF	L
63M	2,4	11	23	4	8.5	75	60	90	0	4-M5	2.5	135	70	140	230
71M	2,4,6	14	30	5	11	85	70	105	0	4-M6	2.5	145	80	160	255
80M	2,4,6,8	19	40	6	15.5	100	80	120	0	4-M6	3	165	145	245	295
90S	2,4,6,8	24	50	8	20	115	95	140	0	4-M8	3	180	165	265	320
90L	2,4,6,8														345
100L	2,4,6,8	28	60	8	24	130	110	160	0	4-M8	3.5	205	175	300	390
112M	2,4,6,8	28	60	8	24	130	110	160	0	4-M8	3.5	225	190	315	420

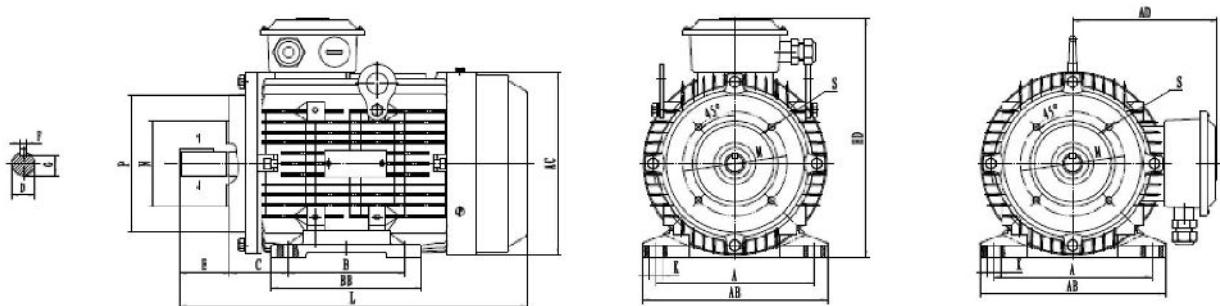
B34 (机座带底脚、端盖上有小凸缘)

机座号 Frame	极数 Poles	安 装 尺 寸 及 公 差 Mounting Dimension														外 形 尺 寸 Overall Dimension								
		A	B	C	D	E	F	G	H	K	M	N	P	R	S	T	AA	BB	HA	AB	AC	AD	HD	L
63M	2,4	100	80	40	11	23	4	8.5	63	7	75	60	90	0	4-M5	2.5	30	110	8	135	135	70	180	230
71M	2,4,6	112	90	45	14	30	5	11	71	7	85	70	105	0	4-M6	2.5	32	120	8	150	145	80	195	255
80M	2,4,6,8	125	100	50	19	40	6	15.5	80	10	100	80	120	0	4-M6	3	32	135	10	160	165	145	215	295
90S	2,4,6,8	140	100	56	24	50	8	20	90	10	115	95	140	0	4-M8	3	34	145	12	180	180	165	235	320
90L	2,4,6,8		125															170						345
100L	2,4,6,8	160	140	63	28	60	8	24	100	12	130	110	160	0	4-M8	3.5	39	186	14	200	205	175	255	390
112M	2,4,6,8	190	140	70	28	60	8	24	112	12	130	110	160	0	4-M8	3.5	45	200	14	230	225	190	290	420

B3 (机座带底脚、端盖无凸缘)

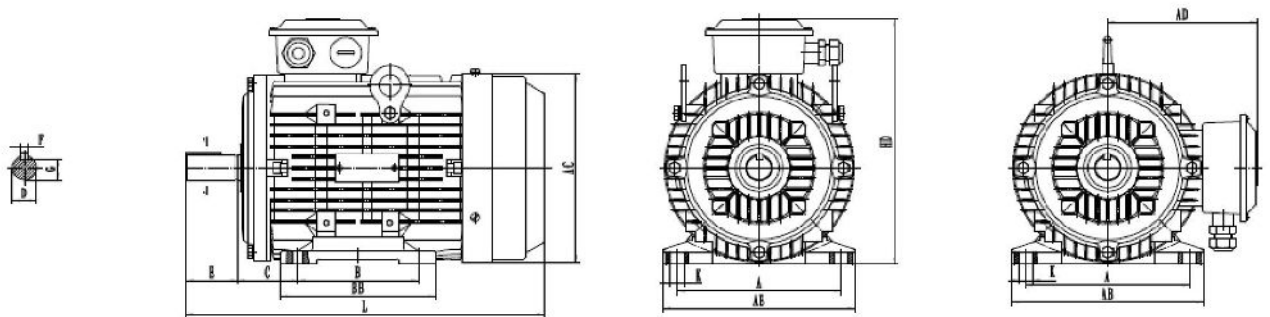

机座号 Frame	极数 Poles	安 装 尺 寸 Mounting Dimension									外 形 尺 寸 Overall Dimension					
		A	B	C	D	E	F	G	H	K	BB	HA	AB	HD	L	
63M	2,4	100	80	40	11	23	4	8.5	63	7			8	135	180	230
71M	2,4,6	112	90	45	14	30	5	11	71	7			8	150	190	255
80M	2,4,6,8	125	100	50	19	40	6	15.5	80	10	130	10	165	215	295	
90S	2,4,6,8	140	100	56	24	50	8	20	90	10	130	10	180	235	320	
90L			125													155
100L	2,4,6,8	160	140	63	28	60	8	24	100	12	176	14	200	255	390	
112M	2,4,6,8	190	140	70	28	60	8	24	112	12	180	14	220	290	420	
132S	2,4,6,8	216	140	89	38	80	10	33	132	12	190	16	265	335	465	
132M			178													230
160M	2,4,6,8	254	210	108	42	110	12	37	160	15	260	20	315	398	610	
160L			254													304

B5 (机座不带底脚、端盖有凸缘)

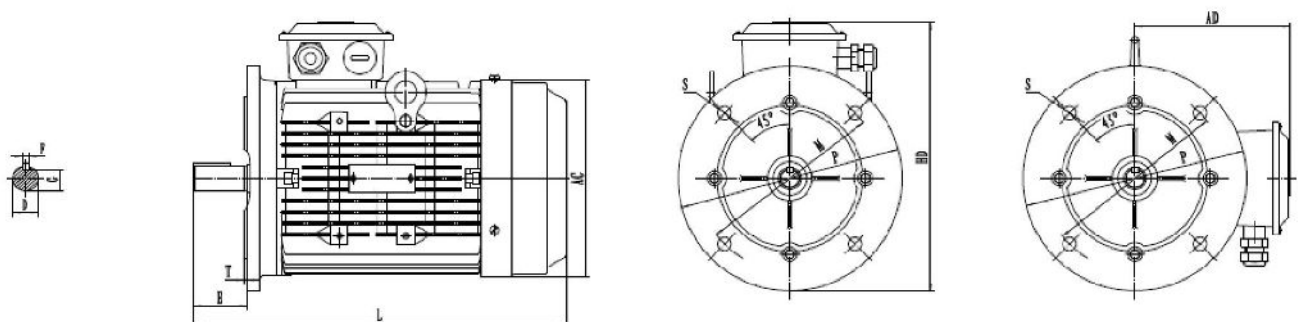

机座号 Frame	极数 Poles	安 装 尺 寸 及 公 差 Mounting Dimension										外 形 尺 寸 Overall Dimension			
		D	E	F	G	M	N	P	R	S	T	AC	AD	HF	L
63M	2,4	11	23	4	8.5	115	95	140	0	4-Φ10	3	135	70	140	230
71M	2,4,6	14	30	5	11	130	110	160	0	4-Φ10	3.5	145	80	160	255
80M	2,4,6,8	19	40	6	15.5	165	130	200	0	4-Φ12	3.5	165	145	245	295
90S	2,4,6,8	24	50	8	20	165	130	200	0	4-Φ12	3.5	180	165	265	320
90L															345
100L	2,4,6,8	28	60	8	24	215	180	250	0	4-Φ15	4	205	175	300	390
112M	2,4,6,8	28	60	8	24	215	180	250	0	4-Φ15	4	225	190	315	420
132S	2,4,6,8	38	80	10	33	265	230	300	0	4-Φ15	4	270	220	370	465
132M															505
160M	2,4,6,8	42	110	12	37	300	250	350	0	4-Φ19	5	320	260	435	610
160L															650

外形及安装 Dimensions

mm

B35 (机座带底脚、端盖有凸缘)

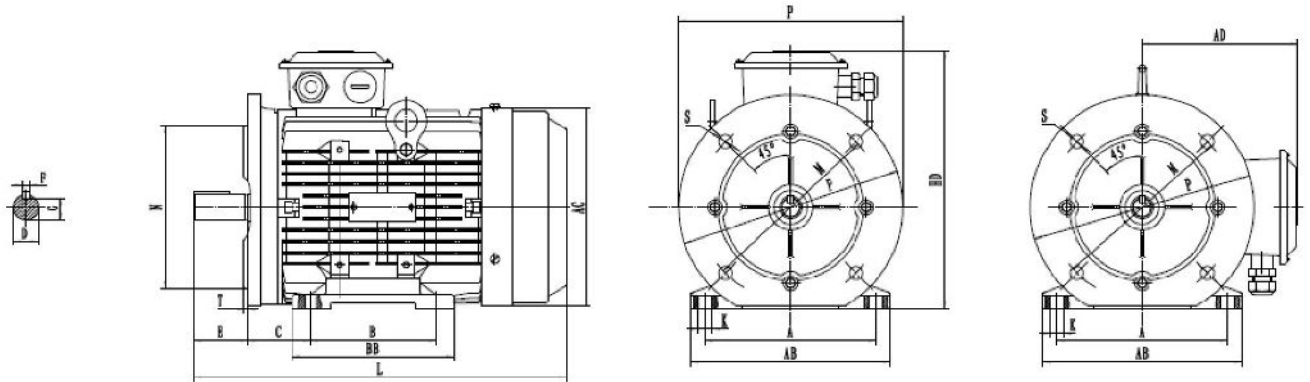

机座号 Frame	极数 Poles	安 装 尺 寸 及 公 差 Mounting Dimension														外 形 尺 寸 Overall Dimension								
		A	B	C	D	E	F	G	H	K	M	N	P	R	S	T	AA	BB	HA	AB	AC	AD	HD	L
63M	2,4	100	80	40	11	23	4	8.5	63	7	115	95	140	0	4-Φ10	3	30		8	135	135	70		230
71M	2,4,6	112	90	45	14	30	5	11	71	7	130	110	160	0	4-Φ10	3.5	32		8	150	145	80		255
80M	2,4,6,8	125	100	50	19	40	6	15.5	80	10	165	130	200	0	4-Φ12	3.5	32	135	10	160	165	145	215	295
90S	2,4,6,8	140	100	56	24	50	8	20	90	10	165	130	200	0	4-Φ12	3.5	34	145	12	180	180	165	235	320
90L			125															170						345
100L	2,4,6,8	160	140	63	28	60	8	24	100	12	215	180	250	0	4-Φ15	4	39	186	14	200	205	175	255	390
112M	2,4,6,8	190	140	70	28	60	8	24	112	12	215	180	250	0	4-Φ15	4	45	200	14	230	225	190	290	420
132S	2,4,6,8	216	140	89	38	80	10	33	132	12	265	230	300	0	4-Φ15	4	55	190	16	265	270	220	335	465
132M			178															230						505
160M	2,4,6,8	254	210	108	42	110	12	37	160	15	300	250	350	0	4-Φ19	5	65	260	20	315	320	260	398	610
160L			254															304						650