

Y2 series 6kV (H355-560) medium-sized high-voltage three-phase asynchronous motor

I. Overview



The power levels, electrical performance, installation dimensions, and tolerances of the Y2 series medium-sized high-voltage three-phase asynchronous motors (frame sizes 355-560) comply with the national standard GB755 "Rotating Electrical Machines - Rating and Performance", the International Electrotechnical Commission standard IEC34-1 "Rotating Electrical Machines - Rating and Performance", and the mechanical industry standards JB/T7593, JB/T10315.1, and JB/T10315.2.

The enclosure protection level of this series of motors is IP54 according to the standards of GB4942.1 and IEC34-5 "Degrees of Protection Provided by Enclosures for Rotating Electrical Machines". If users require other protection levels, they can be supplied separately.

The cooling method of this series of motors is IC411 according to the standards of GB/T1993 and IEC34-6 "Cooling Methods for Rotating Electrical Machines".

The structure and installation type of this series of motors are IMB3 (horizontal with feet), which complies with GB997 and IEC34-7 "Code for Construction and Installation Types of Electric Machines".

The stator adopts an external press-fit structure. The stator winding utilizes Class F insulation materials and anti-corona materials. The winding ends are fixed using a special binding process, ensuring firmness and reliability. The entire stator is treated with vacuum pressure impregnation (VPI) Class F solvent-free paint. As a result, the motor exhibits excellent and reliable insulation performance, moisture resistance, and impact resistance.

This series of electric motors features two types of squirrel-cage rotors: cast aluminum and copper bar. The cast aluminum rotor is made of pure aluminum through casting, ensuring no rotor bar breakage and reliable use. When the motor rotor adopts a copper cage rotor, the rotor bars and end rings are welded using medium frequency welding, and the rotor copper bars undergo a slot-inside fastening process, thus providing high reliability.

II. Model Description:

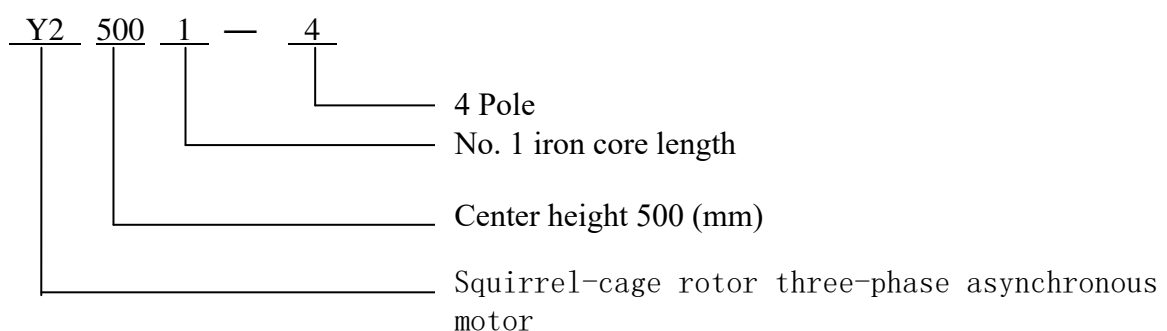

Y2 系列电动机型谱 (6kV)

Y2 series motor model composition (6kV)

机座号 Frame		同步转速 r/min			
		3000	1500	1000	750
		功率 kW			
355	1	185	185	—	—
	2	200	200		
	3	220	220	160	
	4	250	250	185	
	5	280	280	200	
400	1	315	315	220	160
	2	355	355	250	185
	3	400	400	280	200
	4	450	450	315	220
450	1	500	500	355	250
	2	560	560	400	280
	3	630	630	450	315
	4	710	710	500	355
500	1	800	800	560	400
	2	900	900	630	450
	3	1000	1000	710	500
	4	1120	1120	800	560
560	1	1250	1250	900	630
	2	1400	1400	1000	710
	3	1600	1600	1120	800
	4	—	—	1250	900

Y2 系列技术数据 (6kV)

Y2 series technical data(6kV)

型号 (Type)	额定 功率 (kW)	定子 电流 (A)	转速 (r/min)	效率 (%)	功率因数 Cos Φ	最大转矩 额定转矩 $\frac{T_m}{T_n}$	堵转转矩 额定转矩 $\frac{T_{st}}{T_n}$	堵转电流 额定电流 $\frac{I_{st}}{I_n}$	飞轮转矩 ($kg \cdot m^2$)	重量 (kg)
Y2-3551-2	185	22.6	2990	93.9	0.84	2.0	0.7	7.0	8	2035
Y2-3552-2	200	24.4	2990	94.0	0.84	2.0	0.7	7.0	8.5	2075
Y2-3553-2	220	26.8	2990	94.2	0.84	2.0	0.7	7.0	9.5	2160
Y2-3554-2	250	30.3	2990	94.4	0.84	2.0	0.7	7.0	10	2215
Y2-3555-2	280	33.1	2990	94.6	0.86	2.0	0.7	7.0	11	2280
Y2-4001-2	315	37.2	2990	94.8	0.86	2.0	0.7	7.0	17	2630
Y2-4002-2	355	41.9	2990	94.9	0.86	2.0	0.7	7.0	18	2700
Y2-4003-2	400	47.1	2990	95.1	0.86	2.0	0.7	7.0	19.5	2830
Y2-4004-2	450	52.9	2990	95.2	0.86	2.0	0.7	7.0	21	2920
Y2-4501-2	500	58.0	2990	95.3	0.87	2.0	0.7	7.0	22	3200
Y2-4502-2	560	64.9	2990	95.4	0.87	2.0	0.7	7.0	24	3300
Y2-4503-2	630	73.0	2990	95.5	0.87	2.0	0.7	7.0	27	3500
Y2-4504-2	710	82.1	2990	95.7	0.87	2.0	0.7	7.0	30	3600
Y2-5001-2	800	91.5	2990	95.6	0.88	2.0	0.7	7.0	61	5360
Y2-5002-2	900	102.8	2990	95.7	0.88	2.0	0.7	7.0	65	5500
Y2-5003-2	1000	114.0	2990	95.9	0.88	2.0	0.7	7.0	69	5640
Y2-5004-2	1120	127.6	2990	96.0	0.88	2.0	0.7	7.0	75	5900
Y2-5601-2	1250	140.6	2990	96.1	0.89	2.0	0.7	7.0	111	5800
Y2-5602-2	1400	157.2	2990	96.3	0.89	2.0	0.7	7.0	119	5860
Y2-5603-2	1600	179.3	2990	96.5	0.89	2.0	0.7	7.0	127	5930
Y2-3551-4	185	22.6	1490	93.7	0.84	2.0	0.8	6.5	19	2120
Y2-3552-4	200	24.4	1490	93.9	0.84	2.0	0.8	6.5	21.5	2220
Y2-3553-4	220	26.8	1490	94.1	0.84	2.0	0.8	6.5	23	2290
Y2-3554-4	250	30.4	1490	94.3	0.84	2.0	0.8	6.5	24.5	2340
Y2-3555-4	280	33.9	1490	94.5	0.84	2.0	0.8	6.5	25.5	2400
Y2-4001-4	315	37.7	1490	94.6	0.85	2.0	0.8	6.5	32	2970
Y2-4002-4	355	42.4	1490	94.8	0.85	2.0	0.8	6.5	34	3080
Y2-4003-4	400	47.7	1490	95.0	0.85	2.0	0.8	6.5	37	3170
Y2-4004-4	450	53.5	1490	95.2	0.85	2.0	0.8	6.5	39	3250
Y2-4501-4	500	58.7	1490	95.3	0.86	2.0	0.8	6.5	52	3500
Y2-4502-4	560	65.7	1490	95.4	0.86	2.0	0.8	6.5	58	3700
Y2-4503-4	630	73.8	1490	95.5	0.86	2.0	0.8	6.5	65	3950
Y2-4504-4	710	83.1	1490	95.6	0.86	2.0	0.8	6.5	73	4200
Y2-5001-4	800	93.5	1490	95.7	0.86	2.0	0.8	6.5	130	5350
Y2-5002-4	900	105.1	1490	95.8	0.86	2.0	0.8	6.5	141	5540
Y2-5003-4	1000	116.7	1490	95.9	0.86	2.0	0.8	6.5	148	5700
Y2-5004-4	1120	130.5	1490	96.0	0.86	2.0	0.8	6.5	156	5800
Y2-5601-4	1250	143.9	1490	96.1	0.87	2.0	0.7	6.5	252	5900
Y2-5602-4	1400	161.0	1490	96.2	0.87	2.0	0.7	6.5	272	5950
Y2-5603-4	1600	183.6	1490	96.4	0.87	2.0	0.7	6.5	305	6020

Y2 系列技术数据 (6kV)

Y2 series technical data(6kV)

型号 (Type)	额定 功率 (kW)	定子 电流 (A)	转速 (r/min)	效率 (%)	功率因数 Cos Φ	最大转矩 额定转矩 $\frac{T_m}{T_n}$	堵转转矩 额定转矩 $\frac{T_{st}}{T_n}$	堵转电流 额定电流 $\frac{I_{st}}{I_n}$	飞轮转矩 ($kg \cdot m^2$)	重量 (kg)
Y2-3553-6	160	20.6	990	93.4	0.8	2.0	0.8	6.0	26	2255
Y2-3554-6	185	23.8	990	93.5	0.8	2.0	0.8	6.0	28	2345
Y2-3555-6	200	25.7	990	93.6	0.8	2.0	0.8	6.0	31	2440
Y2-4001-6	220	27.5	990	93.8	0.82	2.0	0.8	6.0	47	3010
Y2-4002-6	250	31.2	990	93.9	0.82	2.0	0.8	6.0	50	3110
Y2-4003-6	280	34.9	990	94.1	0.82	2.0	0.8	6.0	53	3200
Y2-4004-6	315	39.2	990	94.3	0.82	2.0	0.8	6.0	57	3250
Y2-4501-6	355	43.6	990	94.5	0.83	2.0	0.8	6.0	64	3600
Y2-4502-6	400	49.0	990	94.6	0.83	2.0	0.8	6.0	73	3800
Y2-4503-6	450	55.1	990	94.7	0.83	2.0	0.8	6.0	81	4000
Y2-4504-6	500	61.1	990	94.9	0.83	2.0	0.8	6.0	90	4200
Y2-5001-6	560	68.3	990	95.1	0.83	2.0	0.8	6.0	177	5370
Y2-5002-6	630	76.7	990	95.2	0.83	2.0	0.8	6.0	184	5500
Y2-5003-6	710	86.4	990	95.3	0.83	2.0	0.8	6.0	191	5630
Y2-5004-6	800	97.2	990	95.4	0.83	2.0	0.8	6.0	202	5830
Y2-5601-6	900	107.8	990	95.6	0.84	2.0	0.7	6.0	388	5930
Y2-5602-6	1000	119.7	990	95.7	0.84	2.0	0.7	6.0	402	6020
Y2-5603-6	1120	133.9	990	95.8	0.84	2.0	0.7	6.0	423	6100
Y2-5604-6	1250	149.3	990	95.9	0.84	2.0	0.7	6.0	450	6150
Y2-4001-8	160	21.7	740	93.2	0.76	2.0	0.8	5.5	50	3020
Y2-4002-8	185	25.1	740	93.3	0.76	2.0	0.8	5.5	52	3090
Y2-4003-8	200	26.7	740	93.5	0.77	2.0	0.8	5.5	56	3150
Y2-4004-8	220	29.3	740	93.7	0.77	2.0	0.8	5.5	61	3260
Y2-4501-8	250	32.8	740	93.9	0.78	2.0	0.8	5.5	65	3600
Y2-4502-8	280	36.7	740	94.1	0.78	2.0	0.8	5.5	73	3800
Y2-4503-8	315	41.3	740	94.2	0.78	2.0	0.8	5.5	82	4000
Y2-4504-8	355	46.4	740	94.4	0.78	2.0	0.8	5.5	91	4200
Y2-5001-8	400	51.6	740	94.5	0.79	2.0	0.8	5.5	177	5380
Y2-5002-8	450	57.9	740	94.6	0.79	2.0	0.8	5.5	184	5510
Y2-5003-8	500	63.4	740	94.8	0.80	2.0	0.8	5.5	191	5640
Y2-5004-8	560	71.0	740	94.9	0.80	2.0	0.8	5.5	202	5850
Y2-5601-8	630	78.7	740	95.1	0.81	2.0	0.7	5.5	480	6200
Y2-5602-8	710	88.5	740	95.3	0.81	2.0	0.7	5.5	510	6240
Y2-5603-8	800	99.6	740	95.4	0.81	2.0	0.7	5.5	535	6320
Y2-5604-8	900	111.8	740	95.6	0.81	2.0	0.7	5.5	560	6400

注：表中性能数据对应的保证值见附表。

Note: These property data shown in table which in correspondence with these guaranteed values are shown in the additive table.

外形及安装尺寸 Dimension

mm

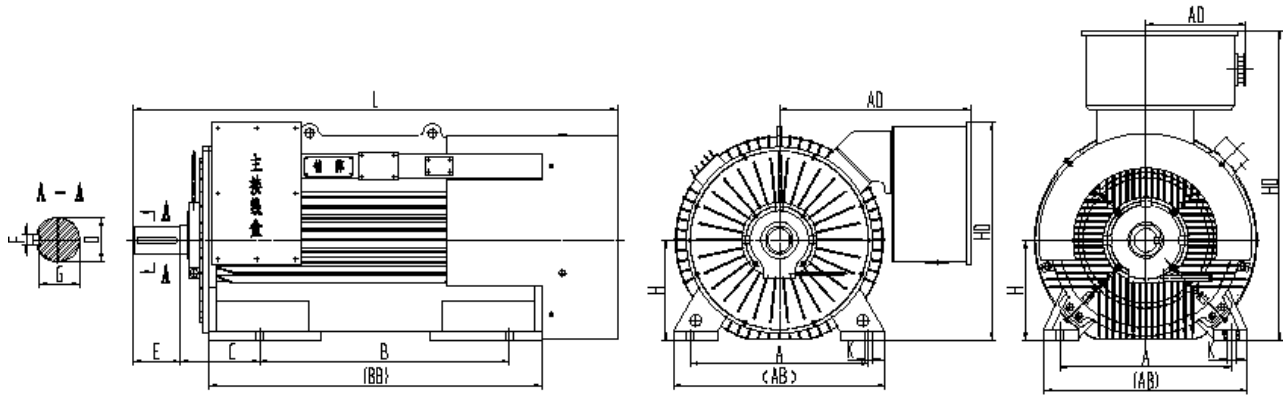

机座号	极数	安装尺寸及公差																外形尺寸									
		mm																mm									
		A		B		C		D		E		F		G		H		K		AD	HD	L	(BB)	(AB)			
基本尺寸	极限偏差	基本尺寸	极限偏差	基本尺寸	极限偏差	基本尺寸	极限偏差	基本尺寸	极限偏差	基本尺寸	极限偏差	基本尺寸	极限偏差	基本尺寸	极限偏差	基本尺寸	极限偏差	基本尺寸	极限偏差	基本尺寸	极限偏差	基本尺寸	极限偏差				
355	2	630	± 1.4	900	± 1.4	254		75		140	± 0.50	20		67.5		355		28	+0.52 0	860	1300	2000	1100	790			
	4~6							100		210	± 0.57	28	0 -0.052	90													
400	2	710		1000				85	+0.035 +0.013	170	± 0.50	22		76		400				900	1400	2200	1200	870			
	4~8								110	± 0.57	28		100														
450	2	800	± 1.75	1120	± 1.75	280		95		170	± 0.50	25		86	0 -0.2	450		35		930	1450	2300	1350	950			
	4								120				109														
	6~8								130	+0.040 +0.015	250	± 0.57	32	0 -0.062	119												
500	2	900	± 2.1	1250	± 2.1	C ^a	± 4.0	110	+0.035 +0.013	210		28	0 -0.052	100		500		42	+0.62 0	970	1550	2500	1490	1100			
	4								130		± 0.57	32		119													
	6~8								140		250		36		128										0 -0.3		
560	2	1000	± 2.1	1400	± 2.1	C ^a		130	+0.040 +0.015	250	± 0.57	32	0 -0.062	119	0 -0.2	560		42		1030	1650	2900	1680	1180			
	4								150						36											138	0 -0.3
	6~8								160						300										± 0.65	40	

 注：C^a 为采用滑动轴承电动机的 C 尺寸，其数值和轴向串动量由制造商和用户商定。